

[54] SPACESUIT THIGH RESTRAINT ASSEMBLY

[72] Inventor: George P. Durney, Dover, Del.  
[73] Assignee: ILC Industries, Inc., Dover, Del.  
[22] Filed: Aug. 5, 1968  
[21] Appl. No.: 750,159

[52] U.S. Cl. ....2/2.1  
[51] Int. Cl. ....A62b 17/00, B63c 11/04  
[58] Field of Search.....2/2.1, 2.1 A, 2, 67, 68;  
438/118, 120, 121; 128/142, 1

[56] References Cited

UNITED STATES PATENTS

2,417,177	3/1947	Richou .....	2/2.1
3,030,626	4/1962	Shepard.....	2/2.1
3,381,303	5/1968	Hazard .....	2/2.1
3,405,406	10/1968	Vykukal .....	2/2.1

FOREIGN PATENTS OR APPLICATIONS

1,038,963 8/1966 Great Britain.....2/2.1

Primary Examiner—Jordan Franklin  
Assistant Examiner—George H. Krizmanich  
Attorney—H. Gordon Dyke and Michael A. Sileo, Jr.

[57] ABSTRACT

A thigh restraint assembly for a pressurized spacesuit which provides improved mobility for the wearer in the area of the thigh and crotch. It comprises thigh convolutes restrained by fabric covers and vertical thigh cables and reinforcement in combination with a plurality of crotch cables and cords passing through the crotch between the front and rear of the suit. The assembly cooperates with the torso and upper legs of the suit to maintain suit stability and to provide stress relief in the area of the joints. It cooperates with a torso block and tackle assembly to provide 90° of forward bending movement.

13 Claims, 9 Drawing Figures

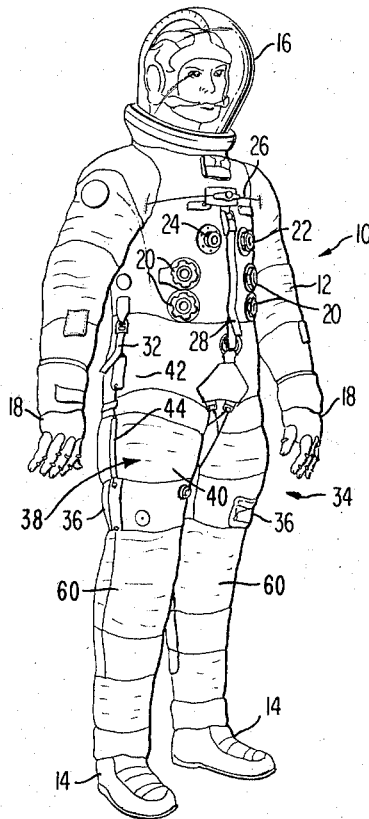

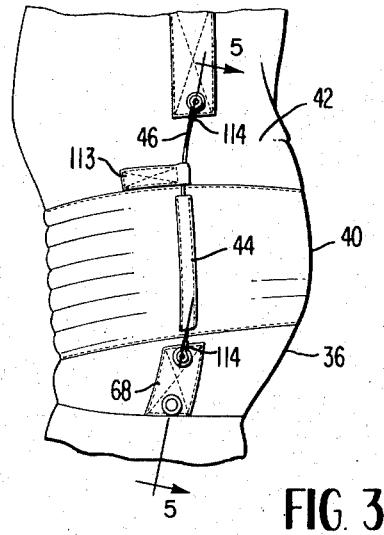
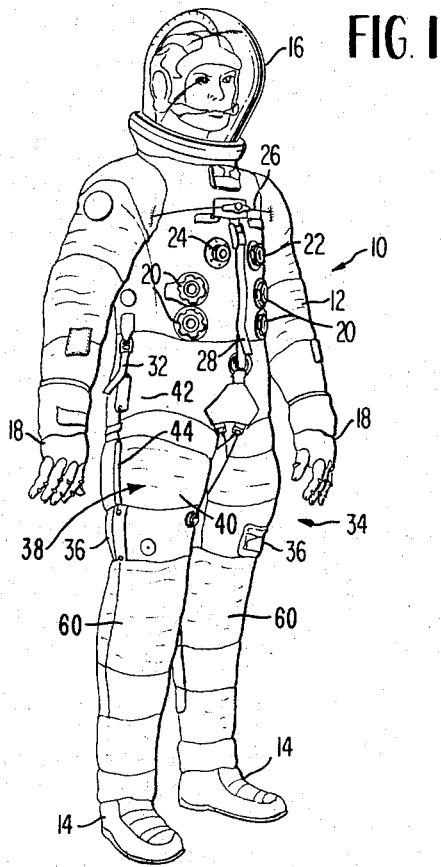

**FIG. 4**

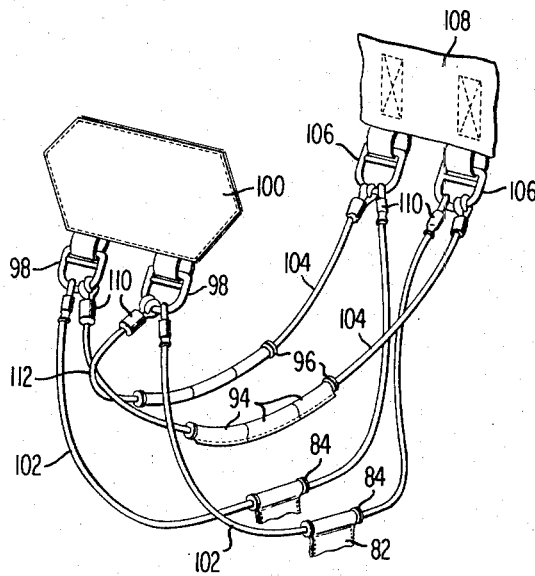
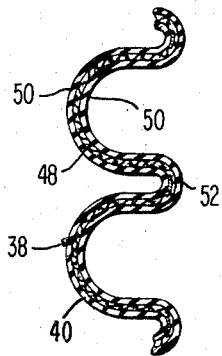

**FIG. 6**

INVENTOR

GEORGE P. DURNEY

BY *Michael A. Sleep*

ATTORNEYS

FIG. 2

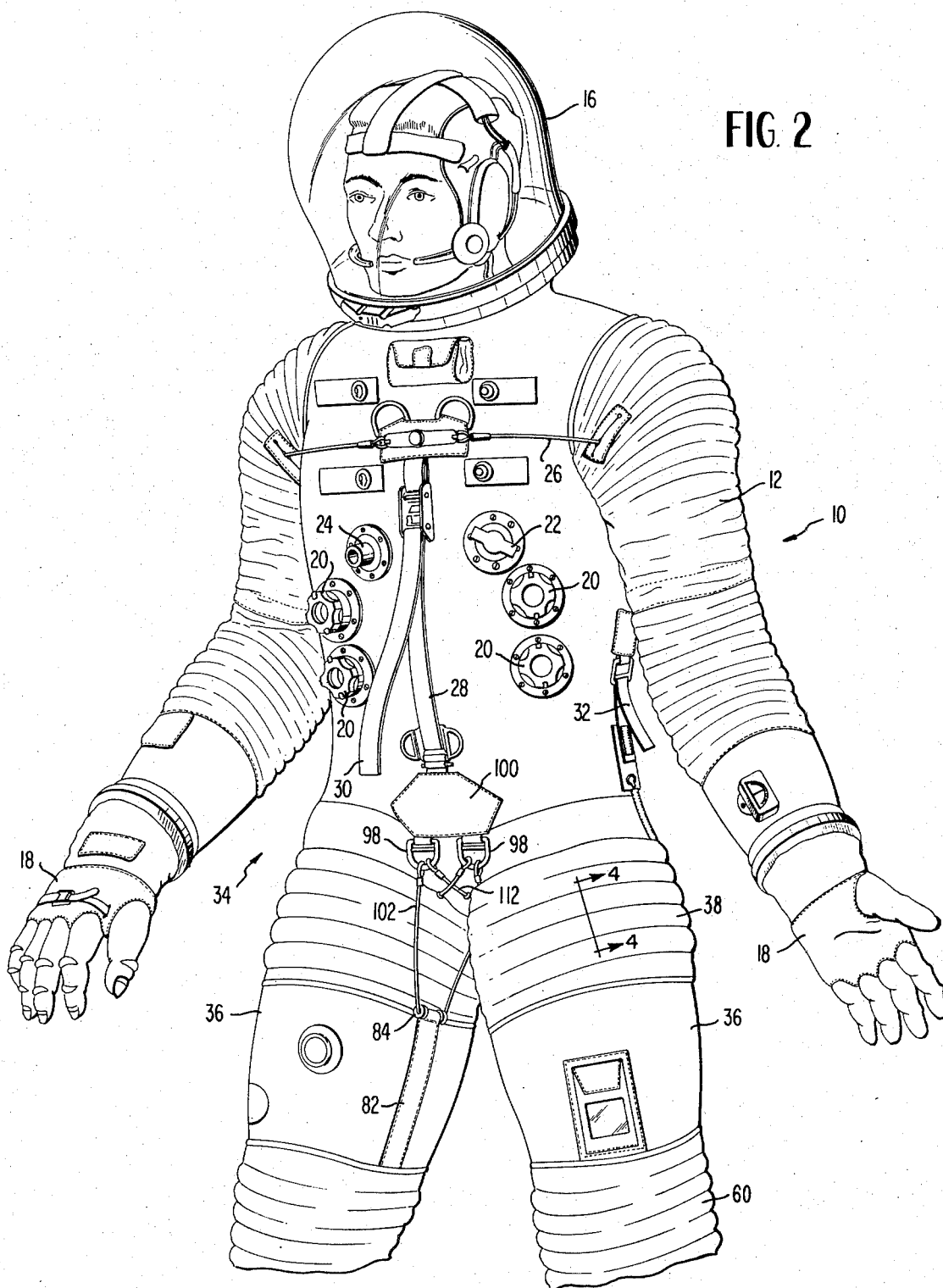

FIG. 5

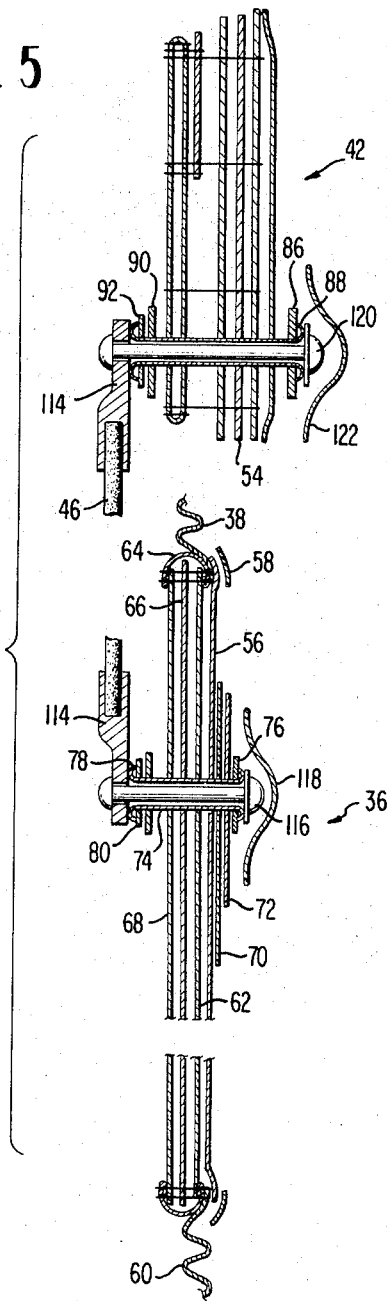

FIG. 7

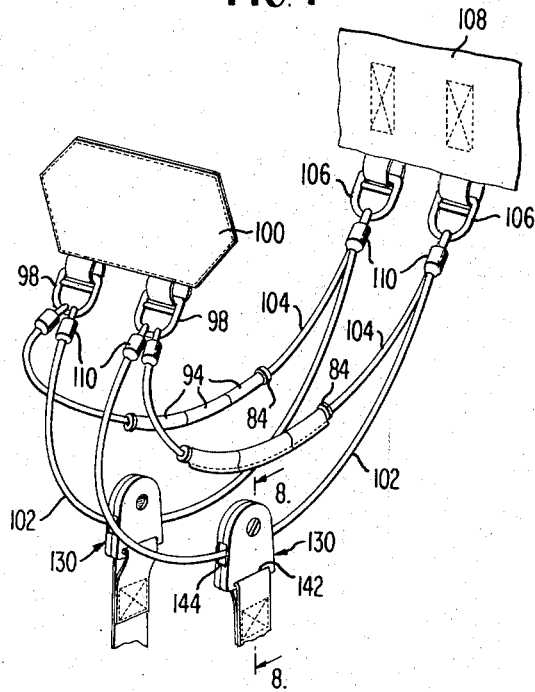

FIG. 8

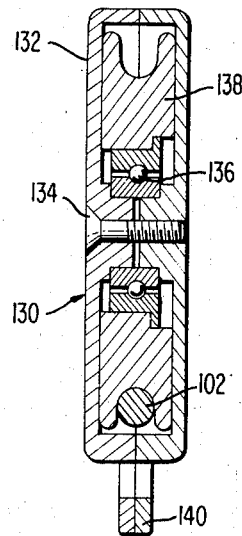
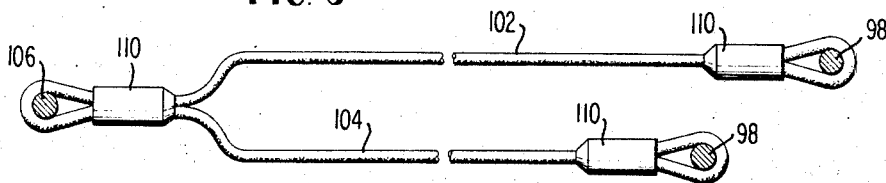

FIG. 9



**SPACESUIT THIGH RESTRAINT ASSEMBLY**

The invention described herein was made in the performance of work under a NASA contract and is subject to the provisions of Section 305 of the National Aeronautics and Space Act of 1958, Public Law 85-568 (72 Stat. 435; 42 U.S.C. 2457).

This invention relates to a spacesuit for use in high altitude, orbital and space missions in rarefied atmospheres or the vacuum of free space, and more particularly is directed to a thigh restraint assembly for a spacesuit worn in the U.S. Apollo Program.

Disclosed in assignee's copending application Ser. No. 750,031 filed Aug. 5, 1968 is a spacesuit constructed to provide a life-supporting environment in rarefied atmospheres and the vacuum of free space. Forming a part of that suit is a combination garment referred to as a pressure garment assembly which includes an inner rubberized fabric pressure sealing layer or bladder and an outer restraint layer of fabric material. The garment is adapted to be inflated to an operating internal pressure by oxygen or other similar life-supporting gas of from 3 to 4 pounds per square inch.

Difficulties have been encountered in prior life-supporting garments in that it is difficult to provide an adequate pressure seal over the astronaut's entire body while at the same time insuring adequate mobility so that the astronaut may flex his limbs and move about to perform necessary tasks while the suit is inflated. That is, under pressure, a rubberized suit forming an envelope surrounding the astronaut tends to become rigid and some provision must be made for at least partly overcoming this rigidity so that the astronaut may move about without expending too much energy so as to unduly tire him or otherwise limit his ability to perform assigned tasks during a space mission.

The present invention is directed to an improved thigh restraint assembly forming a portion of the spacesuit pressure garment assembly designed to permit a wide degree of movement by the astronaut at the waist and hip regions of the suit with a minimum of effort. The thigh restraint assembly is located between the lower torso and upper leg of the suit and is constructed to maintain stability of the hip joint throughout its range of operation by providing axial and lateral restraint. The assembly is closely tailored to conform to actual body contours and when utilized creates a breakpoint at the groin which approximates that of the natural body breakpoint, thus enhancing mobility. The assembly also provides stress relief in the crotch and outer thigh areas.

The center of restraint is balanced with the center of pressure at the leg and torso juncture to effect an erect structure or straight frontal plane at that point. The vertical centerline of the torso and leg closely parallels the frontal plane. During hip flexion, the thigh restraint assembly tends to maintain a dynamic center of rotation to promote equal stress distribution throughout the angular range of movement.

The spacesuit pressure garment assembly permits 90° of flexion and extension in the hip area with a minimum of effort. This total range results from the combined operation of the thigh restraint assembly and a torso restraint strap. The torso restraint strap assembly normally enables approximately 20° of flexion while the thigh restraint assembly contributes approximately 70° of movement to the overall 90° range. These two

systems may be operated independently but their combined use results in a more satisfactory and less strenuous movement. Foreshortening of the hip frontal area by use of the torso strap tends to eliminate the bunching which otherwise tends to occur in the groin area upon bending. This contributes to reduced pressure points or areas of body irritation across the lower abdominal region and in addition lessens the torque movements. The two assemblies once actuated are capable of retaining a given position without effort on the part of the wearer. This feature is especially desirable during period of sustained sitting.

It is therefore one object of the present invention to provide an improved spacesuit for supporting life in a rarefied atmosphere and in the vacuum environments of outer space.

Another object of the present invention is to provide an improved thigh restraint assembly for a spacesuit.

Another object of the present invention is to provide an improved thigh restraint assembly adapted to cooperate with an improved torso assembly to permit 90° bending at the wearer's waist with a minimum of effort on the part of the wearer.

Another object of the present invention is to provide a combination sealing and restraint assembly adjacent the thigh of a spacesuit which permits greater freedom of movement in the areas of the groin and lower abdomen when the suit is pressurized.

These and further objects and advantages of the invention will be more apparent upon reference to the following specification, claims and appended drawings, wherein:

FIG. 1 is a perspective view of a pressure garment assembly forming a part of a spacesuit constructed in accordance with the present invention;

FIG. 2 is a perspective view of the spacesuit of FIG. 1 from a different angle with the lower portion of the suit omitted;

FIG. 3 is a side view of the thigh portion of the pressure garment assembly of FIGS 1 and 2;

FIG. 4 is a partial cross section through the thigh convolute of the suit as shown in FIG. 2;

FIG. 5 is a diagrammatic vertical section through the thigh portion of the suit illustrating the manner of connecting the outer thigh restraint to the hip and thigh cones;

FIG. 6 is a perspective view showing the details of the crotch restraint cables of the suit of FIGS. 1-5;

FIG. 7 is a perspective view of a modified crotch cable assembly usable in the suit of FIGS. 1-5;

FIG. 8 is a vertical section through one of the pulleys forming a part of the cable assembly of FIG. 7; and

FIG. 9 is a plan view of one of the double crotch cables of the embodiment shown in FIG. 7.

Referring to the drawings, the spacesuit of the present invention, generally indicated at 10 in FIG. 1, comprises a pressure garment assembly 12 contoured to the individual astronaut's body and formed with integral boots 14, a removable transparent helmet 16, and removable gloves 18. The pressure garment 12 is adapted to be worn over suitable undergarments, including an inner comfort liner and a liquid cooling undergarment. For extravehicular activity, the entire pressure garment 12 is covered by a thermal insulating layer (not shown) referred to as a thermal micrometeo-

roid garment which protects the astronaut outside the spacecraft from intense sunlight and from micrometeoroid bombardment as might be occasioned in space or during exploration of the lunar surface.

Pressure garment assembly 12 is adapted to be internally pressurized to approximately 3 to 4 pounds per square inch by a life-supporting gas, such as oxygen, by way of a plurality of connectors, generally indicated at 20, on the front of the suit. The oxygen not only pressurizes the suit but is breathed by the astronaut and also acts to cool the astronaut's body and carry away water vapor and waste gases. Also provided on the front of the suit is a cooling water connector 22 through which water is supplied to the undergarment worn by the astronaut during extravehicular activity and an electrical connector 24 for establishing electrical connection to body monitors within the suit and also establishing electrical connection to microphones and earphones within the helmet by means of which the astronaut communicates with other astronauts and/or the spacecraft. During extravehicular activity, the various fluid supplies and electrical power are coupled through the above-described connectors by way of umbilicals to a portable life-support pack carried by the astronaut on his back so that the astronaut may be completely self-sufficient outside the spacecraft for limited periods of time. When the astronaut is within the spacecraft, the back pack is normally removed and the umbilicals may be connected to the life-support system of the spacecraft or the umbilicals may be completely removed, in which case the astronaut relies upon pressurized gas within the vehicle cabin for life support. For greater comfort and mobility within the spacecraft, the helmet 16 and gloves 18 may be removed.

Connected to the breast of the suit and passing through the shoulders is a continuous cable 26 forming a part of a shoulder restraint assembly. Extending vertically of the suit front just beneath this cable is a block and tackle strap assembly 28 including a strap 30 which the astronaut may grasp and pull to shorten or lengthen the front of the suit. This block and tackle assembly 28 aids the astronaut in bending forward and in sitting and tends to relieve pressures on the astronaut during prolonged sitting. If desired, similar straps 32 may be provided at each side of the torso portion of the suit to assist the astronaut in sideways bending at the hips.

As previously mentioned, the pressure garment assembly 12 comprises an inner rubberized fabric layer or bladder which acts to seal the gas within the suit and an overlying fabric layer which restrains the bladder to prevent it from ballooning out or unduly stretching under internal pressure. At the shoulders, elbows, wrists, thighs and knees, the bladder is corrugated to form substantially constant volume convolutes to permit flexure at these locations and each convolute is provided with a protective fabric restraint cover. The thigh restraint assembly, generally indicated at 34, includes portions of the lower torso and the upper leg. Referring particularly to FIGS. 3 and 4, they show a thigh cone restraint 36 for each leg, a thigh convolute 38 and a thigh convolute cover 40. The thigh convolute cover 40 is a patterned part made from 7 ounce Nylon cloth and is stitched to the lower torso 42 and the thigh cone 36 with Nylon thread. The cover 40 acts as a restraining member for the thigh convolute 38 and is so

designed to provide relief or easement at the rear of the leg to accept elongation of the convolute during bending. A ½ inch strip of Nylon tube 44 is sewn vertically to the outboard side of the convolute cover 40. Its purpose is to enclose a portion of the outer thigh restraint cable 46, thereby insuring that the cable and the cover remain aligned with the vertical centerline during forward flexure.

The thigh convolute 38 is a cylindrical bellows having a near constant volume displacement and permits dimensional extension along the aft thigh area during bending. The convolute is an integrated bladder and restraint structure consisting of a Nylon Tricot restraint framework 48 dipped in Latex rubber indicated at 50. Nylon reinforcements 52 are integrated into the root of each convolution to accept hoop surface tensions. The end rims of the convolutes are reinforced to provide an adequate surface for attachment of the convolute to the lower torso 42 and thigh cone 36 which is a part of the upper leg portion of the suit. The restraint materials of the lower torso and thigh cone are sewn to the convolute in the manner illustrated in FIG. 5. The torso bladder 54 and thigh cone bladder 56 are cemented to the inner rims of the convolute with a neoprene adhesive. A chloroprene tape 58 is then cemented over the seam for added protection against leakage or delamination of the seam.

Thigh cone 36 acts as a spacer between the knee convolute 60 and thigh convolute 38. Referring to FIG. 5, it consists of an inner bladder 56 and an outer restraint layer 62 of 7 ounce Nylon cloth. The upper and lower raw edges of the restraint are enclosed in a 3 ounce Nylon twill binding 64. The attachment for the outer thigh restraint cable 46 is reinforced at the outside with a pair of 1½ inch wide Nylon webbings 66 and 68 while the inside is reinforced with a laminated Nylon and rubber reinforcement 70 and cover 72.

A flanged eyelet 74 passes through a grommet washer 76 on the outer thigh cone, through the reinforced thigh cone structure, another grommet washer 78, and then through an eyelet washer 80. The flanged eyelet 74 is then formed over to compress the materials and to provide an attachment for the outer thigh restraint cable 46. The inner thigh cone is reinforced similarly to the outer thigh cone illustrated in FIG. 1. The flanged eyelet, however, is not used but is replaced by a Nylon ribbing 82 (FIGS. 2 and 6) which is folded over itself and sewn to the reinforcement webbing 66 and 68 in such a way as to provide a channel for insertion of the Nylon inner thigh cable guide 84.

Referring to FIG. 5, the lower torso 42 is reinforced similarly to the outer thigh cone 36 of that figure. A grommet washer 86 is placed onto a flanged eyelet 88, which is then passed through the reinforced area from the bladder side. A grommet washer 90 and an eyelet washer 92 are installed onto the flanged eyelet post. The other post is then formed to provide an attachment point for the outer thigh restraint cable 46.

Referring to FIG. 6, three strips of 1 inch wide Nylon webbing 94 are looped, folded over and sewn side by side into the inner juncture of the thigh convolute 38 and the lower torso 42. The looped strips hold the crotch cord sleeves 96 in place. Two D-rings 98, which protrude from the front D-ring reinforcement cover 100, are used to anchor the inner thigh cables 102 and crotch cords 104.

A D-ring assembly 106 is also sewn on each side of the slide fastener assembly 108 in the buttock area. These D-ring assemblies are the rear terminals for crotch cords 104 and thigh cables 102. The crotch cords 104 are cut from  $\frac{1}{8}$  inch solid braid Nylon cord or wire and are first secured to the front D-rings 98 with a swaging sleeve 110. The cords are then fed through the crotch cable guides 96 and firmly secured to the rear D-ring assemblies 106 with similar swaging sleeves 110. The cords 104 cross over each other as at a point designated by numeral 112 on the front of the torso prior to entering the crotch cable guides 96. The function of the crotch cables 104 is to create breaklines in the crotch area which will increase crotch mobility and maintain crotch/limb angle during pressurized conditions. The cords also act as restraining members for the torso crotch and assist in controlling movement of the leg.

The thigh cables 102 are cut from Nylon-coated stainless steel cable or nylon-coated braided wire and are secured at one end to the front D-ring 98 with a swaging sleeve. The cable is then fit through the inner thigh cable guides 84 which may be in the form of plastic tubes attached to the upper leg portions and adapted to slidably receive cables 102 and secured to the rear D-ring assembly 106 with swaging sleeves. The purpose of inner thigh cables 102 is to provide axial restraint for the inside of the thigh convolute to adjust the crotch angle without impairing thigh mobility. The thigh cables 102 in sliding through the thigh cable guide 84 create an arc about which the leg is free to rotate. A thigh cable guide patch tape 113 (FIG. 3) is sewn to the lower torso 42 and acts as a cable guide.

The Nylon-coated stainless steel outer thigh restraint cable 46 has a swaged terminal 114 on each end. The purpose of this cable is to assume approximately 50 percent of the axial limb load. The lower end of the outer thigh cable is anchored to thigh cone 36 by a rivet 116 which passes through flanged eyelet 74. A circular chloroprene tape patch 118 (FIG. 5) is cemented to the bladder over the rivet to effect an airtight seal. The cable passes through the thigh cone tape 44, through the thigh cable guide patch tape 112 and is secured by a rivet 120 which passes through the lower torso side reinforcement eyelet. The rivet head on the bladder side is covered by a circular chloroprene tape patch 122.

FIGS. 7-9 show a modified crotch restraint assembly similar to that of FIG. 6 and with like parts bearing like reference numerals. In the embodiment illustrated in FIG. 7, crotch cables 104 do not cross as they do at point 112 in FIG. 6 and are attached to the D-ring assemblies 98 outside of the thigh restraint cables 102 rather than between these cables as in FIG. 6. In FIG. 7, the thigh restraint cables 102 each pass through a pulley, one of which is indicated by dashed lines at 130 in that figure, and is shown in cross section in FIG. 8. Each pulley 130 comprises a housing 132 formed in two halves and joined by a central threaded screw 134. Mounted in the housing is a ball bearing 136 about which rotates a Nylon roller 138. The lower end of the two halves of the housing form a projection 140 defining a slot 142 by means of which the pulley is attached to the looped end of inner thigh restraint tape 82. The housing 132 is provided with front and rear openings, such as the opening indicated by dashed lines at 144 in

FIG. 7, so that the respective thigh cable 102 may be threaded through the pulley and underneath the roller 138 as illustrated in FIG. 8. In this embodiment, the cable guides 84 of FIG. 6 are omitted since the pulley 130 acts as a cable guide for the thigh cables 102. In this embodiment, the crotch cables 104 and thigh cables 102 are formed of the same material, preferably, Nylon-coated braided metal wire and the ends of the cables are joined together by swage sleeves 110 so that they are joined as a unit to the rear D-ring assemblies 106. FIG. 9 illustrates in plan view the respective outlines of the thigh restraint cables 102 and the crotch cables 104, the former being substantially longer than the latter.

It is apparent from the above that the present invention provides an improved thigh restraint assembly for pressure garments. The construction in combination with the torso strap permits 90° of flexure and extension in the hip area of the wearer with a minimum of effort and the thigh restraint assembly contributes approximately 70° of this movement. The assembly includes a novel external thigh vertical cable construction particularly adapted to resist axial loads and to prevent elongation of the thigh convolute which it overlies and helps restrain. At the same time, the thigh cables permit flexing of the thigh joint through actuation of the substantially constant volume bellows formed in the bladder and additionally restrained by the bladder cover. Interiorly, the thigh joint is restrained by a pair of novel thigh restraint cables which pass through cable guides or pulleys attached to the inner thigh area of the leg and secured by reinforcement to the thigh cone separating the thigh and knee convolutes. Stress relief in the crotch area of the suit is provided by a breast block and tackle assembly in combination with crotch cables secured to the juncture of the thigh cables passing through cable guides secured to the juncture of the lower torso and thigh bellows. The crotch cables create breaklines in the crotch area which increase crotch mobility and maintain crotch/limb angle during pressurized conditions. The cords also act as restraining members for the torso crotch and assist in controlling movement of the leg. The thigh cables provide axial restraint for the inside of the thigh convolute to adjust the crotch angle without impairing thigh mobility and the sliding movement of the thigh cables creates an arc about which the leg is free to rotate. The assemblies once actuated are capable of retaining a given position without serious effort on the part of the wearer since the center restraint is balanced with the center pressure at the leg and torso juncture to effect an erect structure or straight frontal plane at that point. The vertical centerline of the torso and leg closely parallels this frontal plane and during hip flexure the thigh restraint assembly attempts to maintain a dynamic center of rotation to promote equal stress distribution throughout the angular range of movement. The assembly is particularly advantageous during prolonged periods of sitting which otherwise can become quite uncomfortable and tiring to the wearer.

The invention may be embodied in other specific forms without departing from the spirit or essential characteristics thereof. The present embodiments are therefore to be considered in all respects as illustrative and not restrictive, the scope of the invention being in-

dictated by the appended claims rather than by the foregoing description, and all changes which come within the meaning and range of equivalency of the claims are therefore intended to be embraced therein.

What is claimed and desired to be secured by United States Letters Patent:

1. A thigh restraint assembly including a pressure suit, said suit having upper leg portions, a pair of flexible thigh joints and a lower torso portion, said thigh restraint assembly comprising a first pair of elongated outer thigh restraining members extending substantially vertically of said suit across said thigh joints between the upper leg portions and the lower torso portion, one of said members being positioned at each side of said suit adjacent the hip portion of said suit, each member operatively connected to one of each upper leg portions; and a second pair of elongated inner thigh restraining members extending substantially vertically of said suit across said thigh joints between the lower torso portion and the upper leg portions, each of said second pair of thigh restraining members operatively connected at the front and rear of said lower torso portion and to one of each upper leg portion, said second pair of restraining members cooperating with said first pair of restraining members to provide improved mobility in the area of the thigh when said suit is pressurized.

2. A restraint assembly according to claim 1 wherein said restraining members comprise cables attached to said suit.

3. The restraint assembly according to claim 1 wherein said cable is slidably secured to an upper leg portion of said suit intermediate its ends.

4. A restraint assembly according to claim 3 wherein a cable guide is secured to each upper leg portion of said suit, said restraint cables passing through said respective cable guides.

5. The restraint assembly according to claim 4 wherein each of said cable guides is a plastic tube and a reinforcing tape securing said plastic tube to said suit.

6. The restraint assembly according to claim 4 wherein each of said cable guides is a pulley and a reinforcing tape securing said pulley to said suit.

7. A thigh restraint assembly including a pressure suit, said suit having a crotch portion, upper leg portions, a pair of flexible thigh joints and a lower torso portion, said thigh restraint assembly comprising a pair of elongated outer thigh restraining members extending substantially vertically of said suit across said thigh joints between the upper leg portions of said suit and the lower torso portion of said suit, one of said members being positioned at each side of said suit adjacent the hip portions of said suit, and each operatively connected to one of each upper leg portion; a pair of inner

thigh restraining cables, each of said cables being attached at its ends to the front and rear of the lower torso portion of said suit and each operatively connected to one of each upper leg portion; means slidably attaching each of said cables intermediate its ends to each upper leg portion of said suit; and a pair of crotch restraining cords connected at their ends to the front and rear of said lower torso portion of said suit and intermediate their ends to said crotch portion.

8. A thigh restraint assembly according to claim 7 including reinforcing patches at the front and rear of said lower torso portion of said suit, a pair of metal rings attached to each of said reinforcing patches, and means securing the ends of said cables and cords to said rings.

9. A thigh restraint assembly including a pressure suit having a crotch portion, a lower torso portion and upper leg portions, a pair of flexible rubber thigh convolutes operatively connected to said lower torso, said thigh convolutes having a tubular fabric restraining cover overlying each of said thigh convolutes, said thigh restraint assembly comprising a pair of outer thigh restraining cables extending substantially vertically of said suit across said convolutes and attached at their respective ends to the upper leg portions of said suit and the lower torso portion of said suit, one of said cables being positioned at each side of said suit adjacent the hip portions of said suit; a pair of inner thigh restraining cables, each of said inner cables being attached at its ends to the front and rear of the lower torso portion of said suit; means slidably attaching each of said inner cables intermediate its ends to each upper leg portion of said suit; and a pair of crotch cords connected at their ends to the front and rear of said lower torso portion of said suit, each said crotch cord being slidably attached intermediate its ends to said crotch portion.

10. An assembly according to claim 9 wherein said thigh convolute covers each are provided with a tubular reinforcing patch receiving said outer thigh restraint cables, reinforcing patches on said lower torso and upper leg portions of said suit, and eyelets securing said outer cables to said reinforcing patches.

11. An assembly according to claim 9 including a block and tackle on the front torso portion of said suit cooperating with said assembly to provide 90° of forward bending movement at the waist of said suit.

12. The assembly according to claim 9 wherein tubular cable guides are attached to said suit, said inner thigh cables and crotch cords passing through said cable guides.

13. The assembly according to claim 9 wherein pulleys are attached to said suit, said inner thigh cables passing through said pulleys.

\* \* \* \* \*

55

60

65