

Oct. 8, 1935.

R. H. GODDARD

2,016,921

MEANS FOR COOLING COMBUSTION CHAMBERS

Filed Feb. 19, 1930

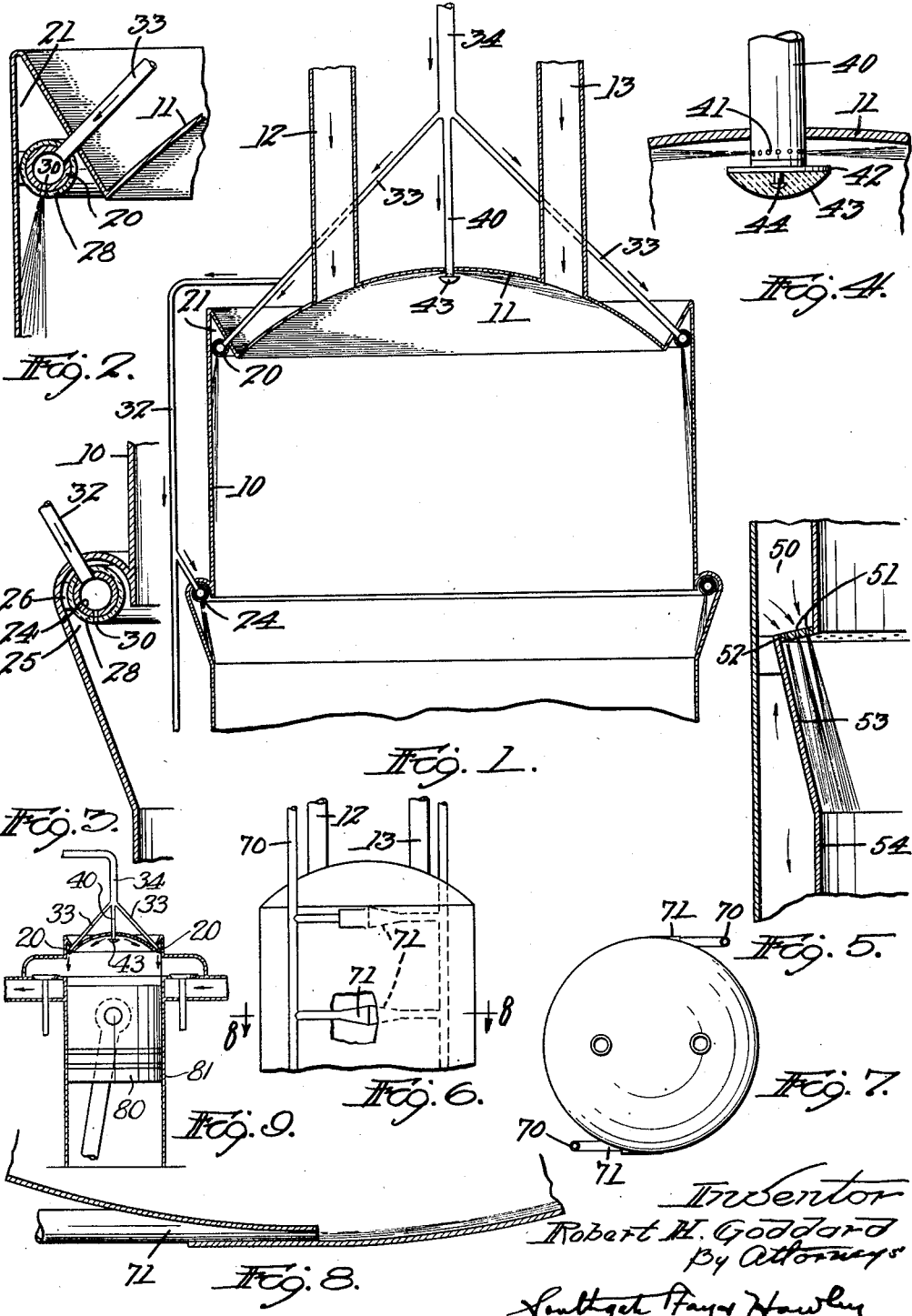

Inventor  
Robert H. Goddard  
By Attorneys  
Sambrecht, Payne & Hawley

# UNITED STATES PATENT OFFICE

2,016,921

## MEANS FOR COOLING COMBUSTION CHAMBERS

Robert H. Goddard, Worcester, Mass.

Application February 19, 1930, Serial No. 429,770

1 Claim. (Cl. 60—46)

This invention relates to means and a method for cooling the walls of combustion chambers or of other highly heated cylinders or containers. The invention is designed to replace or supplement the usual means of cooling by water jackets or by other cooling applications externally of the cylinder, as such external applications have been found impractical under very high temperature conditions and particularly when used in continuous combustion apparatus.

It is the object of my invention to provide means for cooling a combustion chamber or similar container by injecting a cooling fluid directly into the container and adjacent a wall or walls thereof.

A further object is to inject the cooling fluid at such angles and in such manner that it will be evenly distributed as a screen over the surface to be cooled and will effectively limit the rise in temperature thereof.

My invention further relates to arrangements and combinations of parts which will be hereinafter described and more particularly pointed out in the appended claim.

Several forms of my invention are shown in the drawing, in which

Fig. 1 is a sectional front elevation of one form of my invention;

Figs. 2, 3 and 4 are enlarged sectional front elevations of details shown in Fig. 1;

Fig. 5 is a partial sectional elevation of a modified construction;

Fig. 6 is a partial front elevation of a second modification;

Fig. 7 is a plan view of the construction shown in Fig. 6;

Fig. 8 is an enlarged sectional plan view, taken along the line 8—8 in Fig. 6; and

Fig. 9 is a sectional elevation showing a further application of my invention.

Referring to Figs. 1 to 4, I have shown my improved cooling means applied to a combustion chamber having a relatively thin side wall 10 and having an arched end wall 11. Inlet pipes 12 and 13 are connected through the end wall 11. Combustible gases or other fuel may be supplied through the pipe 12 and air, oxygen, or other oxidizing medium through the pipe 13, the construction as shown being adapted to continuous combustion.

A pipe 20 extends around the combustion chamber at its upper end and is preferably mounted in an annular recess 21. One or more additional pipes 24 extend around the wall of the chamber at intermediate points and are prefer-

ably supported in recesses 25 as plainly shown in Fig. 3.

The pipes 20 and 24 are supported in their recesses 21 or 25 by spaced attaching members 26 and are preferably coated with a layer 28 of heat-resisting or insulating material. The pipes 20 and 24 are provided with a large number of fine openings 30, so positioned that streams of fluid, whether gas or liquid, issuing therefrom will be projected downward along the adjacent wall of the combustion chamber and will form a screen thereover.

The pipes 20 and 24 are connected by branch pipes 32 and 33 to a supply pipe 34 through which the cooling fluid is fed to the combustion chamber.

The fluid supplied through the pipe 34 will be under suitable pressure provided by a pump or pressure tank of any usual construction.

An additional pipe 40 extends through the arched upper end 11 of the chamber and is provided with an annular series of openings 41 adjacent an enlarged end flange 42 provided with an insulating coating 43 molded about a stud or screw 44 projecting from the lower surface thereof. Gas or liquid forced outward through the holes 41 will be spread along the arched upper end surface 11 and will be in relatively close contact therewith.

The cooling fluid fed through the pipes 20, 24 and 40 may be itself combustible, or of a nature to support combustion, or it may be simply an inert gas or liquid, but in any case it is found by actual test that such a cooling fluid, whether gas or liquid, and whether combustible, supporting combustion, or inert, will in all cases be extremely effective in cooling the walls of a combustion chamber or other heated container. The walls will be maintained intact under temperature conditions which would entirely destroy cylinders or other containers having the usual jacketed construction. In one actual test, a temperature of over 3000° F. was maintained for a considerable period in a combustion chamber having walls of sheet steel only 1/64" thick, and the walls were in good condition at the end of the test.

Even when high temperature conditions are maintained over a long period of time, as in the case of continual combustion apparatus, my improved method of cooling continues effective and no objectionable heating of the cylinders or combustion chamber wall takes place. Furthermore, the size of the combustion apparatus may be materially reduced by the use of my invention,

as the refractory linings heretofore found necessary may be very greatly reduced in thickness or may be entirely eliminated where my improved cooling means is in use.

5 Where the fluid supplied is in liquid form, it will ordinarily be changed to vapor as it escapes from the openings 30, at the same time absorbing much latent heat from the wall and adjacent atmosphere. The vapor then forms a species of  
10 screen adjacent the chamber wall and the effective cooling or protective action thereof continues.

In the construction shown in Fig. 5, the cooling fluid, instead of being conducted through pipes,  
15 is supplied through a hollow wall or jacket space 50 and enters the cylinder through small holes 51 in an annular perforated plate or ring 52, mounted at the upper end of an offset or recess 53 in the cylinder side wall 54. The holes 51 are  
20 at such an angle that the streams of cooling fluid pass downward alongside and closely adjacent the wall 54, as in the construction previously described.

In the construction shown in Figs. 6 to 8, the  
25 cooling fluid is supplied through pipes 70 to nozzles 71 preferably disposed at opposite sides of the combustion chamber and directed circumferentially, so that a flow of cooling fluid around the cylinder is provided from pairs of diametrically  
30 opposite nozzles. The fluid having been thus distributed around the cylinder, will be carried lengthwise of the cylinder by movement of the combustion gases and the cooling effect will be similar to that previously described.

35 While I have shown and described my invention as applied to a chamber in which continuous combustion takes place, it will be evident that my invention is not limited thereto but is equally applicable to an intermittent explosion chamber  
40 having the usual piston 80 and cylinder 81, as shown in Fig. 9, and to other containers which are subjected to extremely high temperature conditions.

45 The composition of the cooling fluid may be widely varied in accordance with operating conditions. If the surfaces to be cooled comprise oxides, an oxidizing fluid is commonly preferred; while if the chamber surfaces consist of metals, a reducing fluid such as liquid or gaseous hydro-

carbons is more effective, or, in either case, a neutral fluid such as gaseous or liquid nitrogen may be used.

Furthermore, the oxidizing or reducing fluid  
5 may take part in combustion or other chemical process within the chamber or may be of such a nature that it does not enter into the processes taking place in the chamber. When used in connection with a process of continuous combustion,  
10 the flow of cooling fluid will preferably also be continuous, but when used in a chamber having intermittent explosions, the flow of cooling fluid may be continuous or may be intermittent in accordance with the timing of the explosions.

15 Having thus described my invention and the advantages thereof, I do not wish to be limited to the details herein disclosed, otherwise than as set forth in the claim, but what I claim is:—

Combustion apparatus and cooling means  
20 therefor comprising a combustion chamber having a thin cylindrical sheet metal side wall, an end wall for said chamber, means to supply a combustion element to said chamber adjacent said end wall, said side wall having a plurality  
25 of openings adjacent said end wall, a nozzle associated with each of said openings and located exterior to the inner surface of the cylindrical side wall of said chamber, and means to supply a liquid under pressure to said nozzles which liquid  
30 takes an active part in combustion, each nozzle having its axis of delivery in a plane substantially perpendicular to the axis of said cylindrical combustion chamber and the axis of  
35 delivery of each nozzle being substantially tangential to the inner surface of said cylindrical side wall and adjacent said end wall, whereby  
40 streams of liquid introduced through said nozzles enter said chamber substantially tangentially at the zone of combustion and circulate circumferentially around said chamber in close engagement with said side wall and adjacent said end  
45 wall, said liquid entering actively into combustion in the zone of combustion adjacent said end wall and being also engaged and spread axially as a cooling film over other portions of said cylindrical side wall by the axial movement of the combustion gases in said cylinder away from the zone of active combustion adjacent said end wall.

ROBERT H. GODDARD.