

[72] Inventors **Albert R. Baginski**
Torrance;
David T. Okada, Hermosa Beach; Edwin O.
Stastny, Santa Ana, all of, Calif.

[21] Appl. No. **780,154**

[22] Filed **Nov. 29, 1968**

[45] Patented **Aug. 17, 1971**

[73] Assignee **Mattel, Inc.**
Hawthorne, Calif.

[56]		References Cited	
UNITED STATES PATENTS			
321,158	6/1885	Thompson.....	294/106
1,307,887	6/1919	Verrette et al.....	294/104
2,429,866	10/1947	Broste	3/1.2
3,527,495	9/1970	Maradyn	294/106 X
3,093,925	6/1963	Greene.....	46/44 X

Primary Examiner—Robert Peshock
 Attorney—Seymour A. Scholnick

[54] **ENVIRONMENTAL SPACE SUIT TOY**
9 Claims, 4 Drawing Figs.

[52] U.S. Cl. 46/39

[51] Int. Cl. A63h 33/30

[50] Field of Search 46/8, 39,
 53, 55, 44, 89, 87, 178, 188; 128/184; 92/92, 180;
 3/1.2; 73/368.4, 368.7, 410; 116/65; 294/106, 106
 X, 111, 115

ABSTRACT: A toy comprising an astronaut figure, a space capsule around the upper portion of the figure, pneumatically operated tools mounted on the capsule, an air pump, and tubes for coupling the pump to the tools, the tubes passing through the capsule to provide the appearance that the astronaut figure is controlling tool operation. One grasping tool has jaws operated by a bellows that is expanded by air pressure. Another tool includes a thrust element mounted on the inner turn of a spirally wound band, the spiral expanding lengthwise when pressured air is applied to it.

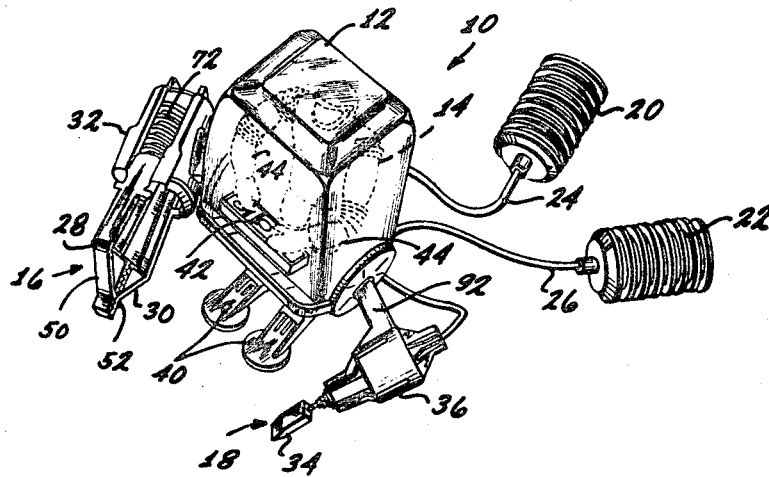

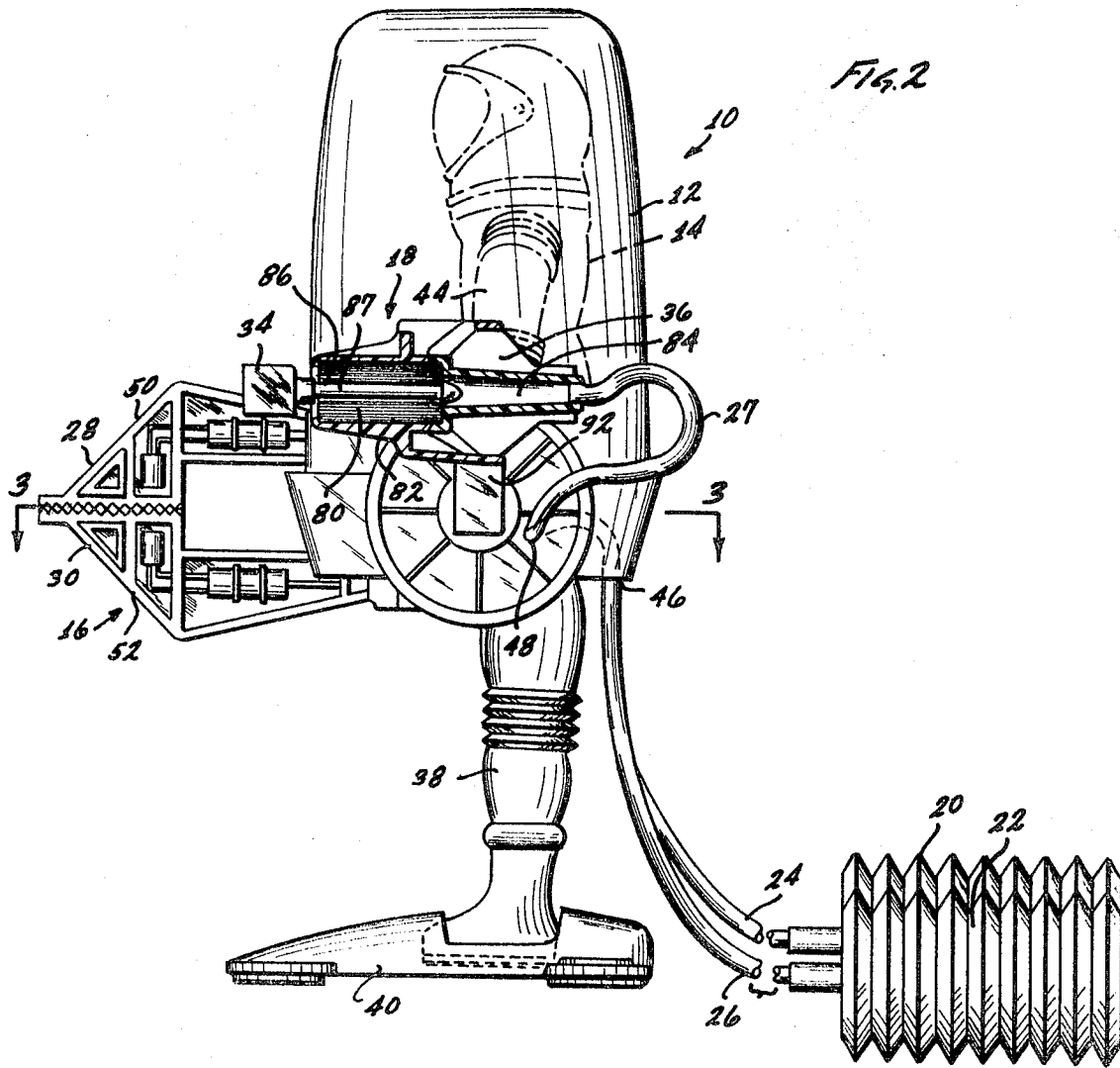

Fig. 2

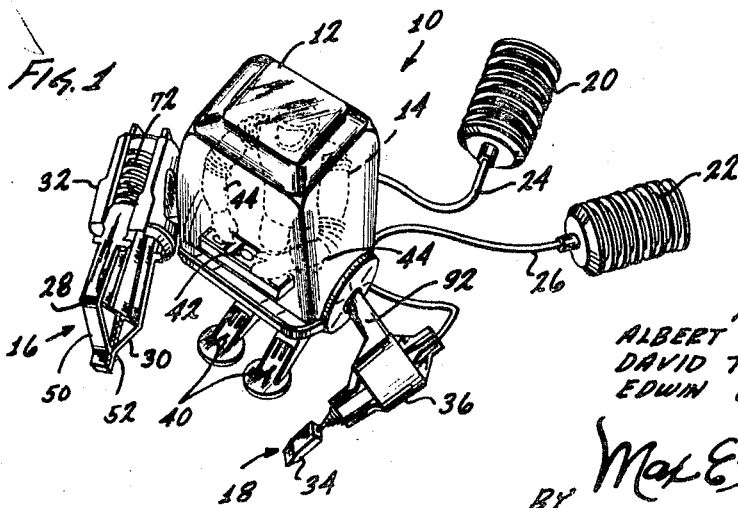

Fig. 1

INVENTORS
ALBERT R. BAGINSKI
DAVID T. OKADA
EDWIN O. STASTNY

BY *Max E. Shirk*
ATTORNEY

FIG. 3

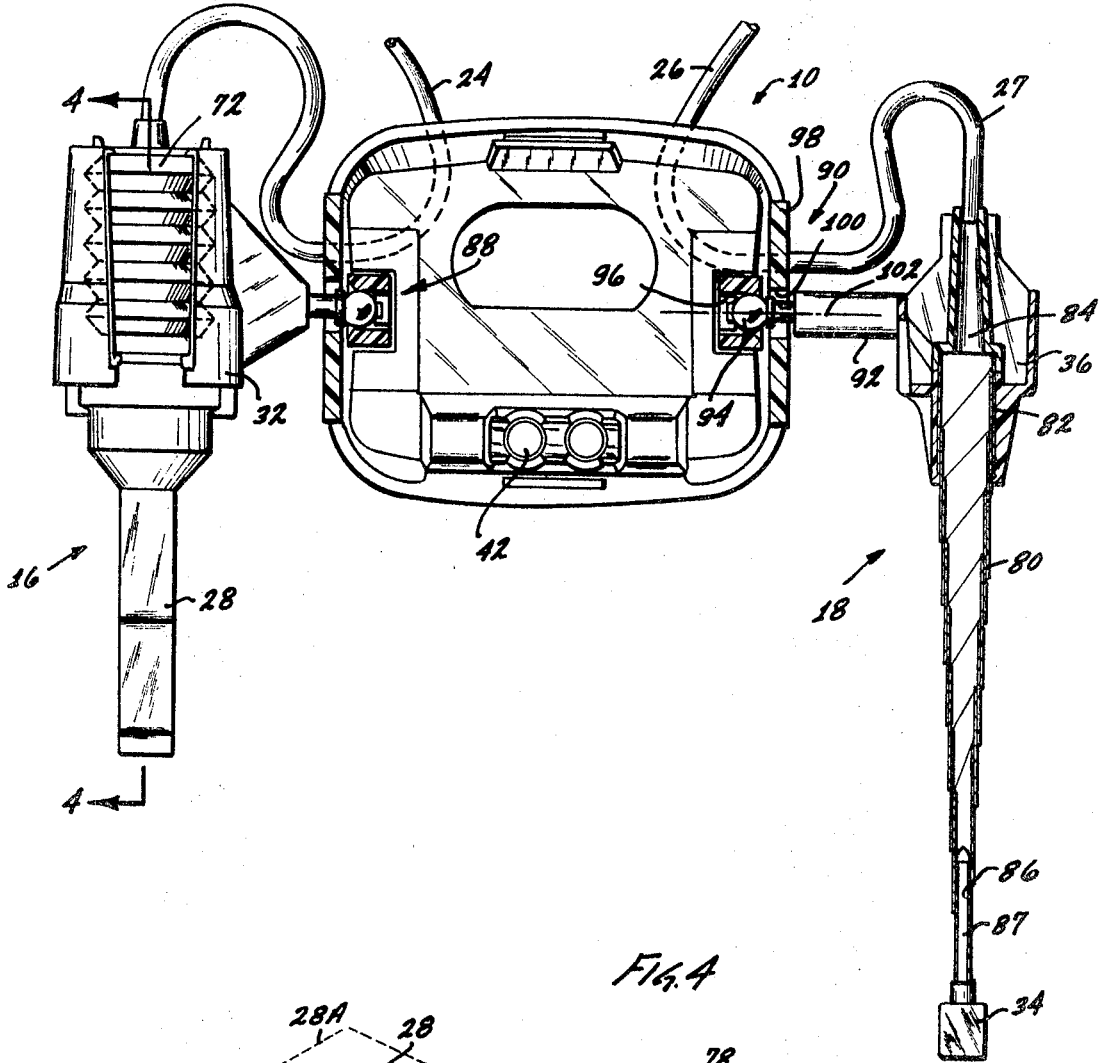
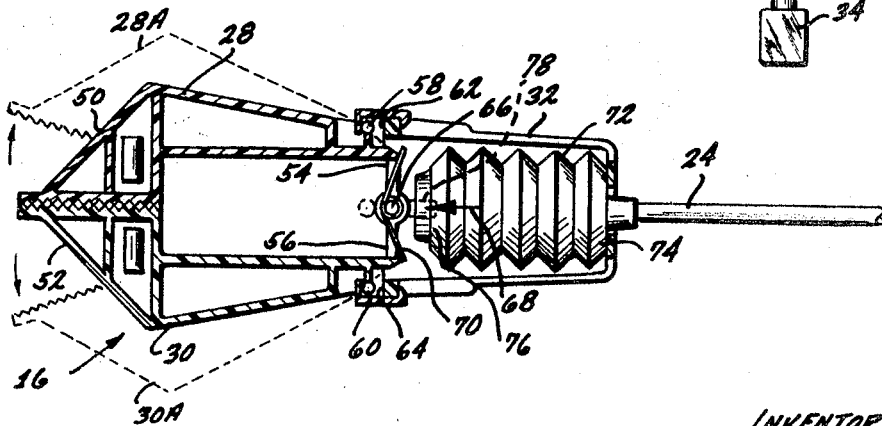

FIG. 4



INVENTORS
ALBERT R. BAGINSKI
DAVID T. OKADA
EDWIN O. STASTNY

BY *Max E. Shirk*
ATTORNEY

ENVIRONMENTAL SPACE SUIT TOY

BACKGROUND OF THE INVENTION

1. Field of the Invention

This invention relates to movable toys.

2. Description of the Prior Art

The entertainment provided by toys can depend upon the degree with which they simulate real or imagined "Adult World" apparatus. For example, U.S. Pat. No. 3,346,989 for Pneumatic Space Capsule by Ryan et al. describes a capsule with arm members that simulate protective arm coverings which would receive the arms of an astronaut in a protective capsule. In the case of action toys, particularly those simulating futuristic or space apparatus, the entertainment value can be further enhanced by novel modes of operation.

OBJECTS AND SUMMARY OF THE INVENTION

An object of the present invention is to provide a novel and entertaining action toy.

Another object is to provide a novel and entertaining action apparatus for toys.

Still another object is to provide a simple pneumatically powered thrusting apparatus.

In accordance with the present invention, an action space toy is provided which includes a capsule for holding an astronaut figure, and tools mounted on the capsule for simulated control by the figure. One tool has a claw that can be opened and closed, while another tool has a space which can be rapidly thrust forward while it rotates. Each tool is pneumatically operated, and receives air pressure pulses from a tube that extends from the space capsule to the tool, to provide the appearance of control by the figure in the capsule. The tubes further extend to air pumps that can be operated by a child to create air pulses that power the tools.

The jaws of the claw tool are pivotally mounted, with ends engaged by a bellows-type cylinder that expands in response to air pulses. The thrusting tool is mounted on the inner turn of a spirally wound band of resilient material, whose outer turn is held by a tool frame. Air pulses applied to the inside of the spiral cause the inner turns to thrust forward and rotate. The thrusting tool is useful not only in toys, but in other applications where a pneumatically operated thrusting apparatus is required.

DESCRIPTION OF THE DRAWINGS

FIG. 1 is a perspective view of a toy constructed in accordance with the invention;

FIG. 2 is a side elevation view, partially in section, of the toy described in FIG. 1;

FIG. 3 is a sectional plan view taken on the line 3-3 of FIG. 2; and

FIG. 4 is a sectional view taken on the line 4-4 of FIG. 3.

DESCRIPTION OF THE PREFERRED EMBODIMENTS

As shown in FIG. 1, the toy 10 comprises a transparent environmental space capsule 12 which surrounds the upper portion of an astronaut doll figure 14. A pair of tools 16 and 18 are mounted on the space capsule, and a pair of hand pumps 20 and 22 are provided to operate the tools 16 and 18, respectively. The pumps 20 and 22 are connected by tubes 24 and 26, respectively, to the tools 16 and 18. Each tube extends through a portion of the space capsule 12 to provide the appearance that the tools are operated by the astronaut figure 14, and also to better support the tubes for strength and neatness.

The tool 16 is a clamping or claw tool which includes two clamping members or jaws 28 and 30 that can open and close to grasp objects. The jaws are pivotally mounted on a tool frame 32 that is mounted on the capsule 12 in a manner that permits it to face in a wide variety of directions. The other tool 18 may be considered to be a thrusting tool, which has a

spadelike thrusting element 34 that can be thrust forward while it rotates. A supporting thrusting tool frame 36 is also mounted on the capsule 12 in a manner that permits it to thrust out the element 34 in a wide variety of directions.

As also shown in FIG. 2, the astronaut figure 14 has legs 38 for supporting itself and the capsule 12, and pads 40 on its shoes for stability. A simulated tool control panel 42 is provided in the capsule, and arms 44 on the figure extend to the panel to indicate operation of the tools by manipulation of panel knobs. A control panel is not necessary, however, to provide the simulated astronaut control of the tools. The air tube 26, which couples the pump 22 to the thrusting tool 18, extends through apertures 46 and 48 in the capsule, so that it appears that the thrusting tool is controlled and powered from the space capsule by the portion 27 of the tube. Corresponding capsule apertures are provided for the other tube 24. Instead of actually projecting through the capsules, however, portions of the tubes could be tied to the outside of the capsule.

As shown in FIG. 4, the jaws 28 and 30 each have an outer jaw portion 50, 52 with serrations, an inner operating end portion 54, 56, and a pivot member 58, 60. The pivot members 58 and 60 are pivotally engaged with bearing slots 62 and 64 on the clamping tool frame 32. The jaws are also pivotally joined together, at a bearing 66 located at the extreme inner ends of the portions 54 and 56. When the bearing point 66 is moved forward in the direction of arrow 68, both jaws are swung open to the positions 28A and 30A. A torsion spring 70, which is looped about the bearing axis 66 and has ends engaged with the jaws, biases the tool to a closed configuration.

The clamping tool is operated by an expandable chamber member 72 of a bellowslike construction. The chamber member, which may be constructed of soft rubber or the like, has an inner end 74 abutting the tool frame. Its opposite end 76 is connected by a rod 78 to the bearing 66 to which the jaws are pivotally joined. When pressurized air is received through the tube 24 to expand the chamber member, the bearing 66 is moved forward and the jaws open. When pressure is removed, the chamber member tends to collapse and the jaws close. The spring 70 increases the closing speed to provide a more positive action. The maximum angle of jaw opening is limited by the large-faced end 76 of the chamber member. The end 76 abuts the inner ends 54 and 56 of the jaws when the clamp is opened wide, to prevent further opening.

The thrusting tool 18, which is shown in greater detail in FIG. 3, includes an operating mechanism 80 in the form of a spirally wound band of resilient material such as Mylar. The spiral has several turns, such as nine, and tends to assume a compressed configuration only as long as the width of the band. However, when pressurized air is admitted through tube 26 to the inside of the spiral mechanism, the mechanism expands to the elongated configuration shown in FIG. 3. In addition to a thrusting motion, the thrusting element 34 makes several rotations as it moves out or back in.

The operating mechanism 80 has an outer turn 82 fastened to the tool frame 36, at a position about a passageway 84 in the frame that connects to the air tube 26. The inner turn 86 of the mechanism is connected to the thrusting element 34. When pressurized air is delivered through the tube 26, the inner turn 86 and its element 34 are thrust forward. In order to reduce air leakage, the band of resilient material is wound into a tight spiral, so the turns are in contact or nearly so even in the elongated configuration. In addition, the thrusting element 34 has a plug 87 which plugs the inside of the inner spiral turn to further reduce air leakage, in addition to serving as the means for attaching the thrusting element to the spiral.

The frames of the clamping and thrusting tools 16 and 18 have couplings 88 and 90 for positioning them in a wide range of directions. For example, the thrusting tool 18 has a connecting member 92 with a ball joint 94 at its end that is engaged with a socket 96 on the capsule. A limit plate 98 on the capsule has a horizontal slot 100 that permits pivoting the tool to the rear and forward, but not up and down. However, the

thrusting tool can be rotated about the axis 102 of the ball joint, which allows it to point in a wide range of directions. The thrusting element 34 can represent a digging tool, and it is desirable to allow it to be directed with a downward component so it hits the ground when operated. The coupling 88 of the clamping tool is constructed in a similar manner to allow the tool to face in a wide range of directions.

The thrusting mechanism of the thrusting tool is useful not only in toys but in a variety of applications where a simple pneumatically operated thrusting and rotating mechanism is useful. Among the applications are output devices for pneumatic logic circuits, and a wide range of applications where cylinder-enclosed pistons or bellows have been used. The spiral band has low mass and moves out and back very quickly. A variety of materials such as Mylar and spring steel can be used for constructing the spiral member, and a wide variety of thrusting elements can be mounted thereon for thrusting motion.

Although particular embodiments of the invention have been described and illustrated herein, it is recognized that modifications and variations may readily occur to those skilled in the art, and consequently, it is intended that the claims be interpreted to cover such modifications and equivalents.

What I claim is:

- 1. A toy for use with a doll figure comprising:
 - a capsule for encompassing at least a portion of said figure;
 - a tool assembly including a movable tool element and pneumatically powered operating means for operating said tool element;
 - means for mounting said tool assembly on the outside of said capsule; and
 - air conduit means extending from said capsule to said tool assembly to power said operating means, whereby to simulate remote tool operation by said doll figure.
- 2. The toy described in claim 1 including:
 - air pump means; and wherein
 - said air conduit means extends from said capsule to said air pump means.
- 3. The toy described in claim 1 wherein:
 - said means for mounting comprises a pivotable joint for rotating said tool to face in a plurality of directions.
- 4. The toy described in claim 1 wherein:
 - said pneumatically powered operating means comprises a

pneumatically expandable manner; and said tool comprises a pair of jaw members, at least a first of said jaw members pivotally mounted for movement against and away from the other jaw member, said first jaw member disposed against to said pneumatically expandable member for movement by it.

5. The toy described in claim 1 wherein: said means for operating said toy comprises a band of flexible material formed in a spiral; and said tool element is mounted on a portion of said band near the inside of said spiral.

6. A toy comprising: a tool frame; pneumatically expandable flexible bellows device mounted on said tool frame; a pair of rigid clamping members separately pivotally mounted on said tool frame on spaced pivots, each having a portion between said pivots disposed adjacent to and engageable by said bellows device for movement thereby to pivot the clamping members; and spring means biasing said clamping members to closed position and air supply means connected to said expandable bellows device.

7. A toy comprising: a frame; a band of resilient material formed in a closely wound spiral, having an outer spiral portion mounted on said frame; a thrust element mounted on an inner spiral portion of said band; and means for applying pressured air to an inner portion of said spiral.

8. The toy described in claim 7 wherein: said thrust element includes a plug portion disposed in substantially sealing cooperation with the inner turn of said spiral.

9. The toy described in claim 7 including: a housing, including means for supporting it on the ground; and wherein said thrust element comprises a digging tool; and said frame is mounted on said housing for pointing with a downward component, to thrust said digging tool against the ground.

45

50

55

60

65

70

75