

Oct. 8, 1940.

R. H. GODDARD

2,217,649

COMBUSTION CHAMBER FOR ROCKET APPARATUS

Filed June 5, 1939

2 Sheets-Sheet 1

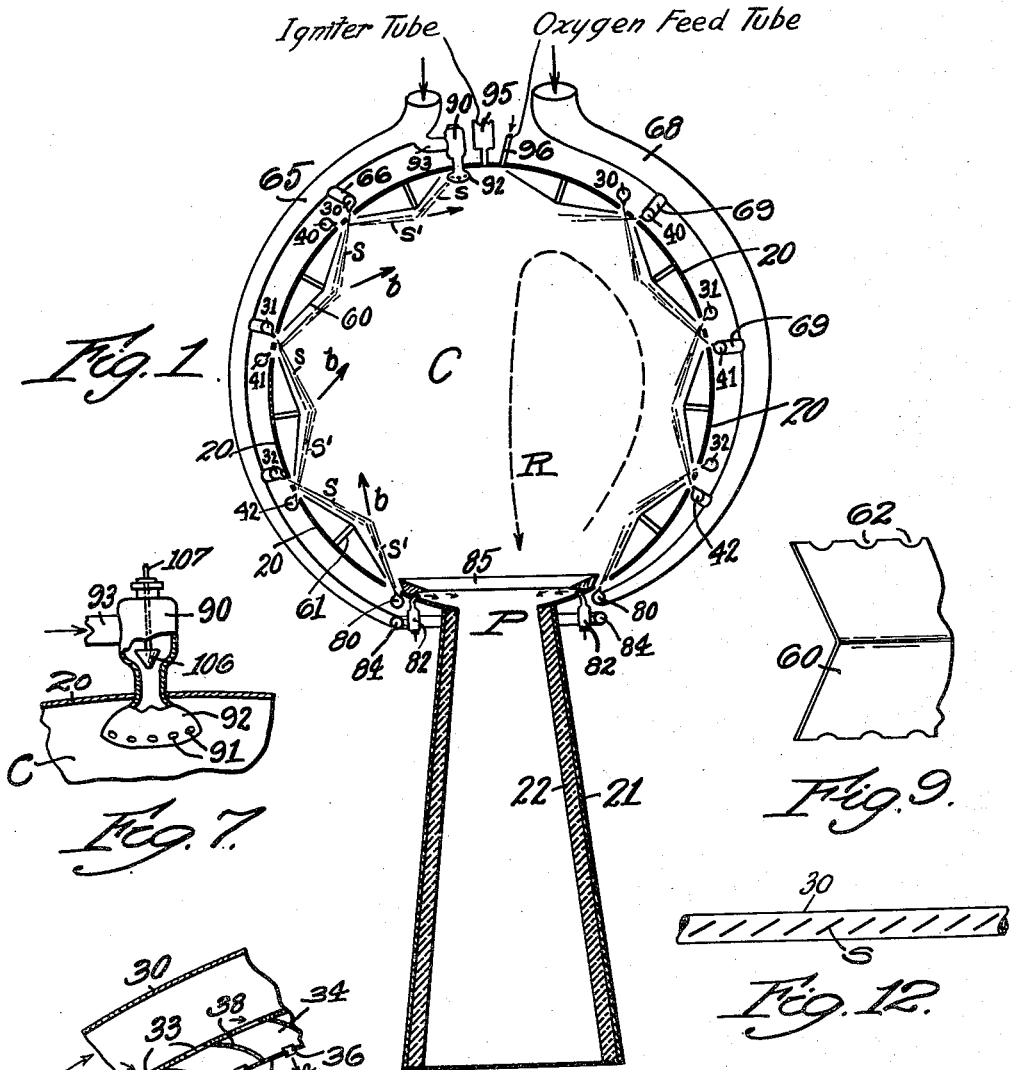

Fig. 1

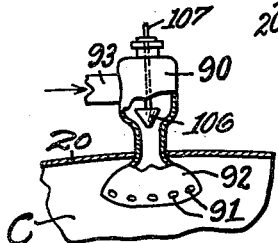

Fig. 7

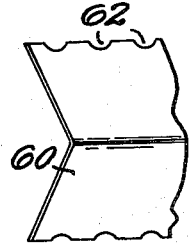

Fig. 9

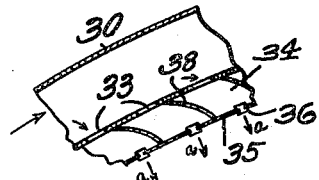

Fig. 8

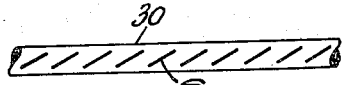

Fig. 12

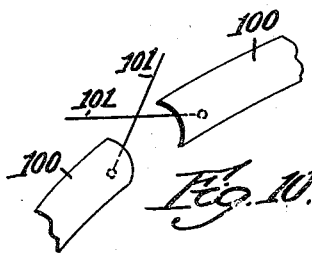

Fig. 10

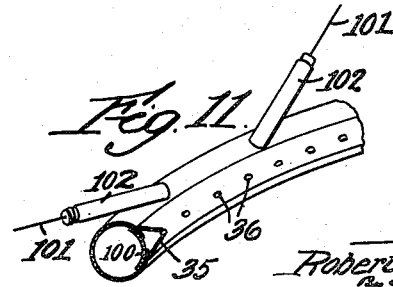

Fig. 11

Inventor
 Robert H. Goddard
 By Attorney
 Chas. P. Hawley

M. J. ...

Oct. 8, 1940.

R. H. GODDARD

2,217,649

COMBUSTION CHAMBER FOR ROCKET APPARATUS

Filed June 5, 1939

2 Sheets-Sheet 2

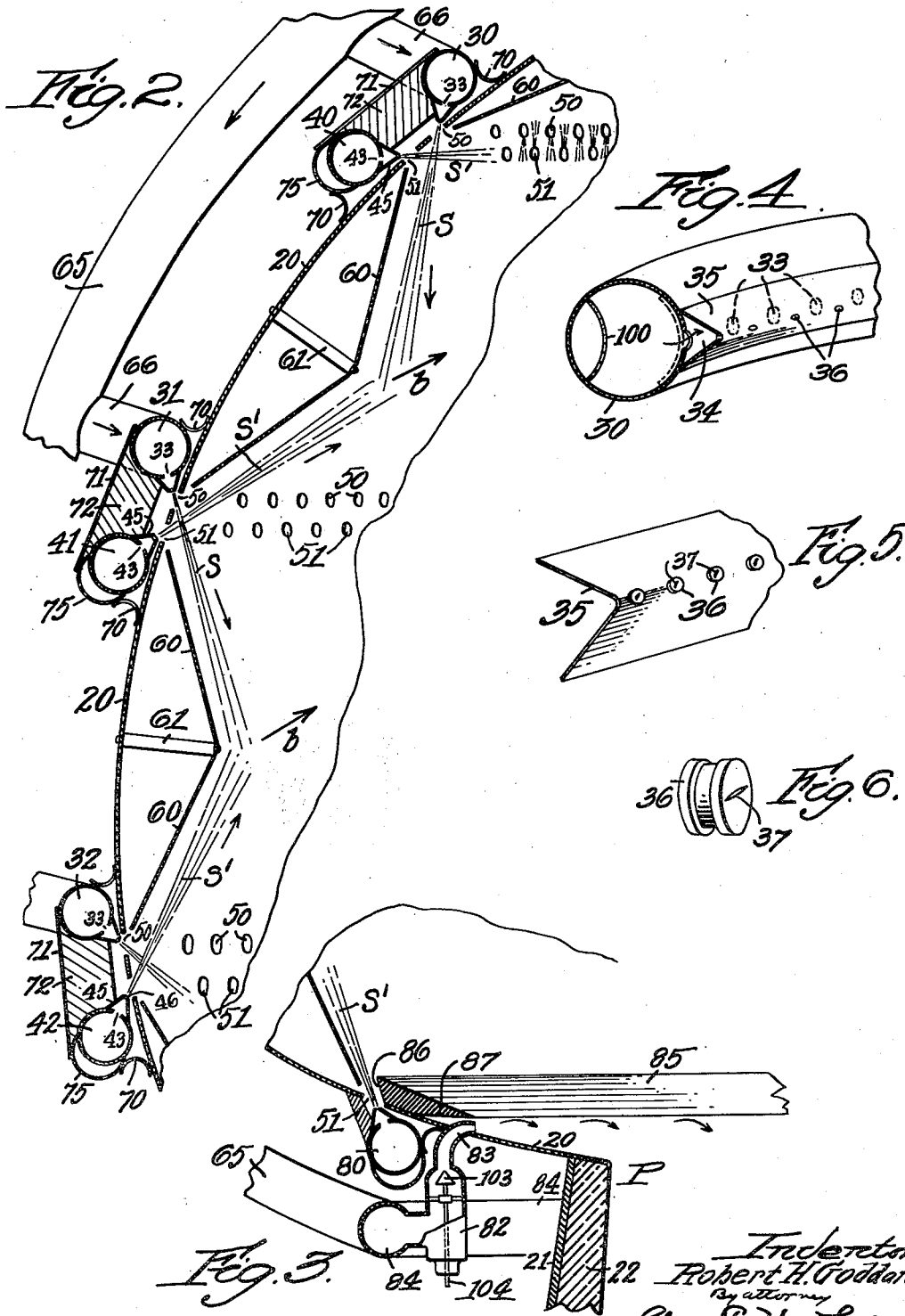

Inventor
Robert H. Goddard
By attorney
Chas. P. Handley

117
27

UNITED STATES PATENT OFFICE

2,217,649

COMBUSTION CHAMBER FOR ROCKET APPARATUS

Robert H. Goddard, Roswell, N. Mex.

Application June 5, 1939, Serial No. 277,491

19 Claims. (Cl. 60—35.6)

This invention relates to rocket apparatus and more particularly to a combustion chamber especially designed for use in such apparatus.

It is the general object of my invention to provide an improved combustion chamber which is of relatively light weight and great strength, and in which effective provision is made for cooling the walls of the chamber without the use of jackets or cooling vanes.

More specifically, I provide a combustion chamber in which a liquid fuel and a liquid oxidizing agent are introduced in a novel manner, so that the walls are effectively protected from overheating and the liquids are very effectively intermingled and consumed.

A further object is to provide a construction in which sprays of a liquid fuel and a liquid oxidizing agent are directed toward each other along sharply intersecting paths and with no substantial contact with deflecting surfaces which might reduce the velocities of the liquid sprays.

My invention further relates to arrangements and combinations of parts which will be hereinafter described and more particularly pointed out in the appended claims.

A preferred form of the invention is shown in the drawings, in which

Fig. 1 is a longitudinal section of my improved combustion chamber and nozzle;

Fig. 2 is an enlarged sectional view of certain parts shown in Fig. 1;

Fig. 3 is an enlarged sectional view of additional parts shown in Fig. 1;

Fig. 4 is a partial perspective view, partly in section, of a gasoline feeding device;

Fig. 5 is a partial perspective view, partly in section, of a nozzle-supporting plate;

Fig. 6 is a perspective view of a nozzle;

Fig. 7 is a front elevation, partly in section, of a gasoline feeding device;

Fig. 8 is a detail longitudinal section through one of the liquid feeding devices;

Fig. 9 is a partial perspective view of a deflecting member;

Fig. 10 is a partial perspective view of a gasoline shut-off plate and operating devices therefor;

Fig. 11 is a partial perspective view of a gasoline feeding tube and associated parts; and

Fig. 12 is a diagrammatic view to be described.

Referring to the drawings, I have shown a combustion chamber C, preferably of spherical contour, and having a wall 20 formed of sheet metal which must be relatively strong but which need not be particularly heat-resistant, as this

spherical chamber is effectively protected from excessive heat by the cooling devices which will be hereinafter described. The chamber C communicates with a nozzle 21, preferably provided with a lining 22 of refractory material, such as an infusible carbide or other material adapted to withstand excessive heat.

Continuous combustion is sustained within the chamber C by injecting sprays of liquid fuel, such as gasoline, and a liquid oxidizing agent, such as liquid oxygen, and by very intimately intermingling these two different sprays, thus forming a highly combustible mixture which is burned in the central portion of the chamber, with the combustion gases escaping through the nozzle 21 and reacting therewith to propel the rocket apparatus forward.

In the following description, the terms "gasoline" and "oxygen" are to be understood as embracing any liquid fuel and any liquid oxidizing agent.

In order to introduce and intermingle the sprays of gasoline and liquid oxygen, I provide a set of three or more annular tubes, as 30, 31, and 32 (Fig. 2) for feeding gasoline and a set of three or more annular tubes, as 40, 41, and 42 for feeding oxygen. While only three pairs of tubes are shown in the drawings, it will be understood that any desired number of tubes may be provided, depending upon the size of the combustion chamber. These annular tubes are disposed in planes perpendicular to the axis of the nozzle 21, and are mounted in closely associated pairs, as 30—40; 31—41 and 32—42.

The construction of each of the gasoline feeding tubes 30, 31 and 32 is as disclosed in Fig. 4, in which the tube 30 is shown as provided with a plurality of radial holes 33, opening into an annular recess or chamber 34 enclosed between the outer wall of the tube 30 and a V-shaped projection 35 in which a series of nozzles 36 are mounted. Each of these nozzles 36 (Fig. 6) produces a flat gasoline spray S of relatively small circumferential width by any well known means, preferably by a narrow slot or opening 37 through which the gasoline is ejected into the combustion chamber as shown in Fig. 2.

Preferably the nozzles 36 are out of line with the holes 33, as shown in Fig. 8, and curved vanes 38 are desirably provided to change the direction of the streams of liquid from the circumferential or tangential flow through the annular tube 30 to flow in a direction substantially perpendicular to the axis of the tube 30, as indicated at a in Fig. 8. The flat sprays are slightly

inclined to the planes of the tubes 30, as indicated in Fig. 12, so that as they spread out they do not interfere.

The oxygen feeding tubes, as 40, 41 and 42, are substantially the same construction as that shown in detail in Figs. 4, 5 and 6 and are provided with holes 43, extensions 45 and nozzles 46, all as previously described.

The sprays S from the gasoline tubes 30, 31 and 32 are directed through spaced openings 50 in the chamber wall 20, and the sprays S' of liquid oxygen from the tubes 40, 41 and 42 are similarly directed through openings 51 in the chamber wall 20. The openings 50 and 51 are preferably staggered as shown in Fig. 2, so that the sprays from adjacent tubes do not substantially intermingle. The sprays are directed at such angles, however, that the sprays S from the tube 30, for instance, directly intercept and intermingle with the sprays S' from the tube 41, while the sprays S from the tube 31 correspondingly intercept and intermingle with the sprays S' from the tube 42.

It will be noted that each spray travels in a direct and unobstructed path to its point of engagement with its opposing spray, so that no friction by a deflecting surface can act to reduce the rate of spray travel.

In order to protect the chamber wall 20 from stray portions of intermingled gas which may be thrown off in an outward direction, I provide annular deflecting members 60 (Fig. 2) which may be secured on the wall 20 by posts 61 and which should be made of a sheet metal having good heat-resistant and heat-conducting properties. Notches 62 (Fig. 9) in the edges of the members 60 equalize the gas pressures above and below the deflecting members.

Gasoline and oxygen are fed to the two sets of tubes in any convenient manner, as by one or more tapered distributing pipes 65 (Figs. 1 and 2), connected by branch pipes 66 to the gasoline tubes 30, 31 and 32, and by one or more tapered pipes 68, connected by branch pipes 69 to the oxygen feeding tubes 40, 41 and 42. Gasoline and liquid oxygen may be supplied to the distributing pipes 65 and 68 from any suitable source. The pipes 65 and 68 are preferably disposed in planes substantially perpendicular to the planes of the gasoline and oxygen feeding tubes.

The gasoline and oxygen feeding tubes are mounted adjacent the outer surface of the wall 20 of the chamber C in any convenient manner, as by annular curved metal strips 70 (Fig. 2). Adjacent tubes may be secured to each other by annular plates 71. The space between the plates 71 and the adjacent tubes should be filled by a packing 72 of non-combustible material, so that the gases from the gasoline and oxygen sprays directed through the openings 50 and 51 may not collect in any considerable amount outside of the chamber C to form an explosive mixture. The packing also prevents the gases from surging back and forth through the openings 50 and 51 and thus disturbing the even distribution of the sprays.

A jacket strip 75 (Fig. 2) is desirable for each oxygen tube as 40, 41 or 42 to preserve the low temperature of the liquid oxygen and to thus prevent choking of the holes 43 and nozzles 46 which would occur if the liquid oxygen were allowed to become warm enough to vaporize.

The volume of liquid oxygen supplied is substantially in excess of the volume of gasoline, the

desired proportions for complete combustion being about three-and-a-half to one. It will be noted that each of the oxygen sprays S' is directed away from the discharge opening P. The oxygen being in greater volume, the direction of travel of the mixture, after the sprays have intermingled, is substantially as indicated by the arrows b in Fig. 1. Consequently, the path of travel of the aggregate intermingled gases is substantially as indicated by the arrow R in Fig. 1, the gases first moving away from the opening P along the outer wall of the chamber C to the inner end thereof, and then returning through the central portion of the chamber and through the discharge opening P to the nozzle 21.

Combustion takes place most largely during the first part of this return movement through the central portion, so that heating of the combustion chamber wall is greatly reduced, both by the protection of the intercepting sprays of gasoline and oxygen, and also by the fact that the actual combustion quite largely takes place in the upper central portion.

In order to protect the lower portion of the chamber C (as viewed in Fig. 1), I provide an additional oxygen feeding pipe 80 (Figs. 1 and 3) which directs its spray S' upward to intercept the gasoline spray S from the tube 32, all as previously described. The pipe 80 is connected to the oxygen distributing pipe or pipes 68 (Fig. 1).

I also provide one or more gasoline feeding devices 82 (Fig. 3) having nozzles 83 adapted to introduce gasoline in a tangential direction above the chamber wall 20 closely adjacent the discharge opening P. This gasoline flows around and over the lower portion of the chamber wall and down over the upper portion of the refractory lining 22 and thus protects these parts from the excessive heat which might otherwise destroy them and provides a reducing atmosphere adjacent the nozzle 21. At this point the gases are fully burned. The devices 82 are supplied from an annular tube 84 connected to the gasoline distributing pipe or pipes 65.

In order to separate the tangential streams of gasoline injected by the nozzles 83 and the oxygen sprays S' from the tube 80, I provide a guard ring 85 having a beveled upper surface 86 adjacent the oxygen openings 51 for the sprays S' and having a second beveled surface 87 overlying the gasoline nozzles 83 and aiding in directing the jets of gasoline circumferentially and toward the discharge opening P. The ring 85 should be of good thermal conductivity.

In order to supply gasoline sprays S to intermingle with the oxygen sprays S' from the upper annular oxygen tube 40 (Fig. 1), I provide a gasoline feeding device 90 (Figs. 1 and 7) having a series of nozzles 91 corresponding to the nozzles 36 previously described and disposed in the enlarged inner or lower end 92 of the device 90, which device is connected by a branch pipe 93 to one of the gasoline distributing pipes 65.

I thus provide a multiplicity of flat sprays S and S' of combustible and oxidizing liquids respectively, which sprays intercept at abrupt angles, so that the two liquids are very effectively intermingled to form a highly combustible mixture. The spray sheets are thin, the drops of liquid are very fine and the rate of approach of the sprays is high.

In order to start combustion in the chamber C, I provide an igniter tube 95 (Fig. 1), and an oxygen feed tube 96 adjacent thereto. The op-

eration of this igniter is fully described in my prior Patent No. 2,090,039 and serves to fill the chamber C with a large flame which effectively ignites the mixture of gasoline and oxygen gases as soon as the sprays S and S' are introduced. This should take place immediately after introduction of the flame, to prevent the occurrence of explosive mixtures in parts of the chamber, the burning of the chamber wall 20 through lack of protecting sprays, and the possible freezing of gasoline on the oxygen nozzles 46.

It is also desirable when stopping combustion in the chamber C that the entrance of gasoline and oxygen through the various nozzles should be simultaneously discontinued. For this purpose I provide annular convex shut-off plates 100 (Figs. 4, 10 and 11) adapted to closely overlie the holes 33 in the gasoline tubes, or the corresponding holes 43 in the oxygen tubes, and to simultaneously close all of the holes in a tube at the same time.

These shut-off plates may be operated by tension wires 101 (Figs. 10 and 11) slidable in packed tubes 102 and adapted to draw the plates together to the position shown in dotted lines in Fig. 4 to close the holes 33 or to spread them apart to the full line position shown in Fig. 4, in which position the flow of liquid through the tube 30 is substantially unobstructed.

Valves 103 (Fig. 3) are provided for the gasoline devices 82 and are movable to closed position by wires 104. A valve 106 (Fig. 7) is also provided for the gasoline feed device 90 and is movable to closed position by a wire 107. Any convenient or suitable mechanism may be provided for simultaneously operating the wires 101, 104 and 107.

The spherical type of combustion chamber is desirable, as it affords maximum strength for minimum weight of material, but axially elongated chambers may also be used to good advantage.

Having thus described my invention and the advantages thereof, I do not wish to be limited to the details herein disclosed, otherwise than as set forth in the claims, but what I claim is:

1. In a rocket apparatus, a nozzle, a combustion chamber associated therewith and having a relatively thin sheet metal outer wall, encircling tubes supplying a combustible liquid and a liquid oxidizing agent respectively to said chamber, and means to direct sprays of both liquids from said tubes into said chamber along sharply intersecting paths.

2. In a rocket apparatus, a nozzle, a combustion chamber associated therewith and having a relatively thin sheet metal outer wall, encircling tubes supplying gasoline and liquid oxygen respectively to said chamber, and means to direct relatively flat sprays of gasoline and oxygen from said tubes into said chamber along sharply intersecting paths, the sprays from adjacent tubes being staggered to avoid interference as they enter the chamber, and sprays from non-adjacent tubes intercepting each other to form an intimate mixture.

3. In a rocket apparatus, a nozzle, a combustion chamber associated therewith and having a relatively thin sheet metal outer wall, encircling tubes supplying gasoline and liquid oxygen respectively to said chamber, and means to direct sprays of gasoline and oxygen from said tubes into said chamber, the sprays from non-adjacent tubes intercepting each other at points relatively near said outer wall.

4. In a rocket apparatus, a nozzle, a combustion chamber associated therewith and having a relatively thin sheet metal outer wall, encircling pairs of tubes to supply gasoline and liquid oxygen respectively to said chamber, and means to direct relatively flat sprays of gasoline and oxygen from said tubes into said chamber along sharply intersecting paths, the sprays from adjacent tubes being staggered to avoid interference as they enter the chamber, and sprays from non-adjacent tubes intercepting each other to form an intimate mixture and said collective sprays forming a liquid screen for said outer wall.

5. In a rocket apparatus, a nozzle, a combustion chamber associated therewith and having a relatively thin sheet metal outer wall, encircling pairs of tubes supplying gasoline and liquid oxygen respectively to said chamber, means to direct sprays of gasoline and oxygen from said tubes into said chamber, said sprays from non-adjacent tubes intercepting each other at points relatively near said outer wall, and deflecting members interposed between said intercepting members and said wall.

6. In a rocket apparatus, a nozzle, a combustion chamber associated therewith and having a relatively thin sheet metal outer wall, encircling pairs of tubes supplying gasoline and liquid oxygen respectively to said chamber, means to direct sprays of gasoline and oxygen from said tubes into said chamber, said sprays from non-adjacent tubes intercepting each other at points relatively near said outer wall, and deflecting members interposed between said intercepting sprays and said wall, each deflecting member forming a flattened V in section and closely underlying the oppositely directed intercepting sprays.

7. In a rocket apparatus, a nozzle, a combustion chamber associated therewith and having a relatively thin sheet metal outer wall, encircling pairs of tubes supplying gasoline and liquid oxygen respectively to said chamber, means to direct sprays of gasoline and oxygen from said tubes into said chamber along sharply intersecting paths, and additional means to inject gasoline sprays adjacent the end of said chamber remote from said nozzle.

8. In a rocket apparatus, a nozzle, a combustion chamber associated therewith and having a relatively thin sheet metal outer wall, encircling pairs of tubes supplying gasoline and liquid oxygen respectively to said chamber, means to direct sprays of gasoline and oxygen from said tubes into said chamber along sharply intersecting paths, and a single oxygen-feeding tube adjacent the discharge opening of said nozzle.

9. In a rocket apparatus, a nozzle, a combustion chamber associated therewith and having a relatively thin sheet metal outer wall, encircling pairs of tubes supplying gasoline and liquid oxygen respectively to said chamber, means to direct sprays of gasoline and oxygen from said tubes into said chamber along sharply intersecting paths, a single oxygen-feeding tube adjacent the discharge opening of said nozzle, and additional means to inject gasoline in circumferential paths adjacent said discharge opening.

10. In a rocket apparatus, a nozzle, a combustion chamber associated therewith and having a relatively thin sheet metal outer wall, encircling pairs of tubes supplying gasoline and liquid oxygen respectively to said chamber, means to direct sprays of gasoline and oxygen from said tubes into said chamber along sharply intersect-

ing paths, a single oxygen-feeding tube adjacent the discharge opening of said nozzle, additional means to inject gasoline in circumferential paths adjacent said discharge opening, and a deflecting guard rail interposed between said additional supplies of oxygen and gasoline.

11. In a rocket apparatus, a nozzle, a combustion chamber associated therewith and having a relatively thin sheet metal outer wall, means to inject and intermingle gasoline and oxygen within said chamber, and means to direct the flow of the mixture of gasoline and oxygen away from said nozzle adjacent the outer wall of said chamber and toward said nozzle in the central portion of said chamber.

12. In a rocket apparatus, a nozzle, a combustion chamber associated therewith and having a relatively thin sheet metal outer wall, means to inject sprays of gasoline and liquid oxygen to said chamber and means to direct said sprays along such paths that they intercept and intermingle, said oxygen sprays being directed away from the discharge opening to said nozzle and being in substantially greater volume than the gasoline, whereby the resultant flow of the mixture of gasoline and oxygen is away from said nozzle adjacent the outer wall of said chamber and toward said nozzle in the central portion of said chamber.

13. In a rocket apparatus, a nozzle, a combustion chamber associated therewith and having a relatively thin sheet metal outer wall, encircling tubes supplying gasoline and liquid oxygen respectively to said chamber, said tubes having a plurality of holes through which the contained liquid flows outward, and a single means to close all of the holes in each tube simultaneously.

14. In a rocket apparatus, a nozzle, a combustion chamber associated therewith and having a relatively thin sheet metal outer wall, encircling tubes supplying gasoline and liquid oxygen respectively to said chamber, said tubes having a plurality of holes through which the contained liquid flows outward, a segmental shut-off plate in each tube effective to simultaneously close all of the holes in the tube co-acting with said plate, and means to circumferentially expand and contract said plate.

15. In a rocket apparatus, a nozzle, a combustion chamber associated therewith and having a relatively thin sheet metal outer wall, encircling tubes supplying gasoline and liquid oxygen respectively to said chamber, a V-shaped projection on one side of each tube providing a recess in

communication with said tube and a plurality of small spray nozzles mounted in an annular series on said projection and in communication with said recess.

16. In a rocket apparatus, a nozzle, a combustion chamber associated therewith and having a relatively thin sheet metal outer wall, encircling tubes supplying gasoline and liquid oxygen respectively to said chamber, a V-shaped projection on one side of each tube providing a recess in communication with said tube, a plurality of small spray nozzles mounted in an annular series on said projection and in communication with said recess, and vanes in said recess to direct liquid to said nozzles.

17. In a rocket apparatus, a nozzle, a combustion chamber associated therewith and having a relatively thin sheet metal outer wall, encircling tubes supplying gasoline and liquid oxygen respectively to said chamber, a V-shaped projection on one side of each tube providing a recess in communication with said tube, and a plurality of small spray nozzles mounted in an annular series on said projection and in communication with said recess, said nozzles having elongated straight openings slightly inclined to a circumferential line through said openings, whereby the edges of sprays delivered therefrom do not interfere.

18. In a rocket apparatus, a nozzle, a combustion chamber associated therewith and having a relatively thin sheet metal outer wall, encircling tubes supplying gasoline and liquid oxygen respectively to said chamber, a V-shaped projection on one side of each tube providing a recess in communication with said tube, and a plurality of small spray nozzles mounted in an annular series on said projection and in communication with said recess, the planes of the substantially flat sprays from said nozzles being slightly inclined to a circumferential line through said openings, whereby the edges of sprays delivered therefrom do not interfere.

19. In a rocket apparatus, a nozzle, a combustion chamber associated therewith and having a relatively thin sheet metal outer wall, pairs of encircling tubes supplying gasoline and liquid oxygen respectively to said chamber, said outer wall having a double series of openings there-through between each pair of tubes, and rings of non-combustible packing filling the spaces between each pair of encircling tubes.

ROBERT H. GODDARD.