

July 6, 1937.

R. H. GODDARD  
COMBUSTION APPARATUS  
Filed Nov. 25, 1935

2,085,800

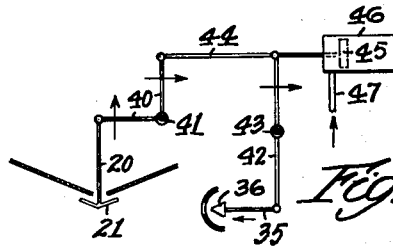
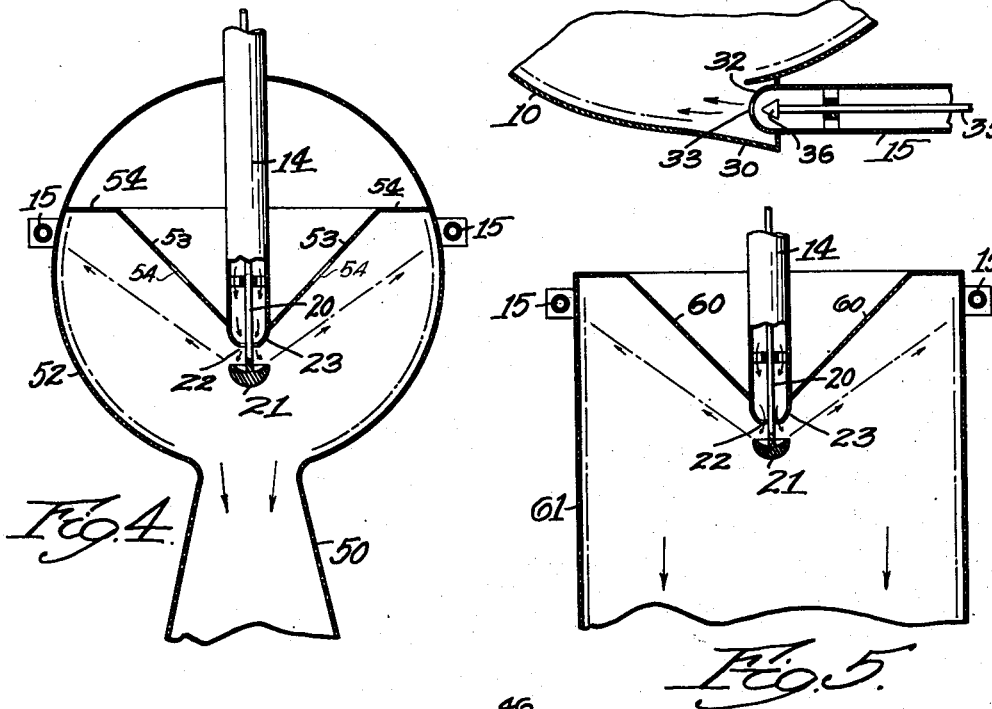
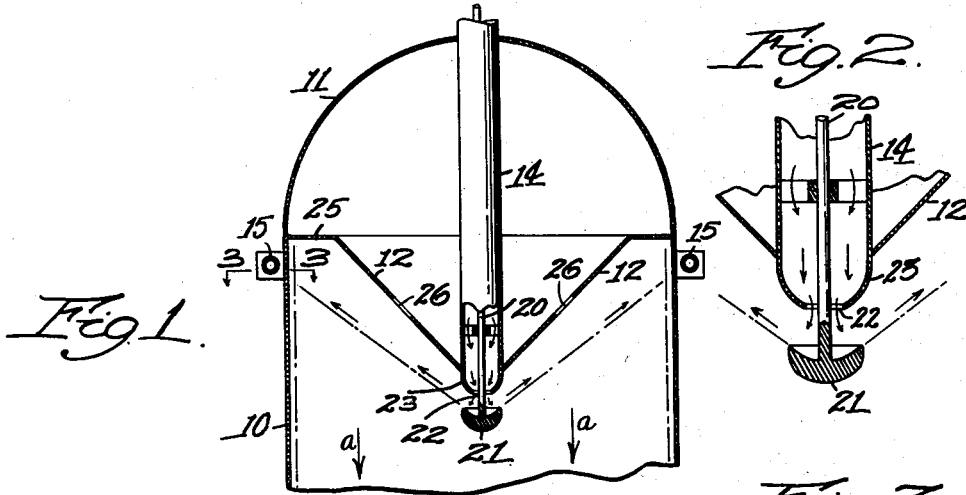

Frederator  
Robert H. Goddard  
by attorney  
Smithgate, Payne & Hawley

# UNITED STATES PATENT OFFICE

2,085,800

## COMBUSTION APPARATUS

Robert H. Goddard, Roswell, N. Mex.

Application November 25, 1935, Serial No. 51,435

7 Claims. (Cl. 60-44)

This invention relates to apparatus for use in effecting the combustion of a mixture of a liquid fuel and a liquid oxidizing agent. The invention further relates to the provision of combustion apparatus of very light weight, which is thereby adapted for use in self-propelled rockets and in other aircraft in which unnecessary weight must be eliminated.

More specifically, my invention relates to that type of combustion apparatus in which one or both of the liquids which supports combustion are utilized as cooling agents for the combustion chamber walls. One form of such apparatus is shown in my prior Patent No. 2,016,921, issued October 8, 1935.

It is the general object of my invention to improve the construction shown in my prior patent, to the end that more complete combustion may be attained in a minimum space and that all danger of explosion may be avoided.

A further object is to provide a construction in which sheet metal walls of reduced thickness may be utilized.

My invention further relates to arrangements and combinations of parts which will be hereinafter described and more particularly pointed out in the appended claims.

Preferred forms of the invention are shown in the drawing, in which

Fig. 1 is a partial sectional elevation of a combustion chamber embodying my improvements; Fig. 2 is an enlarged sectional elevation of certain of the parts shown in Fig. 1;

Fig. 3 is an enlarged detail sectional plan view, taken along the line 3-3 in Fig. 1;

Figs. 4 and 5 are views similar to Fig. 1 but showing modified constructions, and

Fig. 6 is a diagrammatic view of certain valve-operating mechanism.

Referring to Figs. 1, 2, and 3, I have shown parts of a combustion chamber comprising a cylindrical side wall 10, a substantially semi-spherical outer rear end wall 11, an inwardly projecting and substantially conical inner end wall 12 and supply pipes 14 and 15 for oxidizing and combustible liquids. Preferably the pipe 14 supplies the liquid oxidizing agent such as liquid air or liquid oxygen and the pipe 15 supplies the liquid fuel such as gasoline. All of these parts are preferably formed of thin sheet steel or of other sheet metal of relatively high strength.

A valve rod 20 is slidable in the supply pipe 14 and is provided at its outer end with a cup-shaped head 21 positioned outside of the restricted open-

ing 22 in the nozzle 23 which forms the outlet of the supply pipe 14.

The conical inner end wall 12 preferably has an annular flat base portion 25 by which it is firmly secured within the cylindrical body 10. The conical inner end wall 12 also has perforations 26 which permit the pressures on both sides of the conical end wall to be equalized and which thus in effect transfer any rearward pressure in the combustion chamber to the dome-shaped outer end wall 11, which is of the section best adapted to resist such rearward pressure.

The supply pipe 15 (Fig. 3) enters the combustion chamber in a substantially tangential direction, the inner end of the supply pipe being preferably located in an offset portion 30 of the cylindrical side wall 10. The supply pipe 15 has a nozzle portion 32 with a restricted opening 33 and has a valve rod 35 slidable therein and provided with a conical head 36.

When the rod 35 and head 36 are pushed inward or to the left in Fig. 3, the opening 33 will be closed and the liquid supply through the pipe 15 will be shut off. Similarly when the rod 20 and head 21 (Fig. 1) for the supply pipe 14 are drawn upward, the head 21 closes the opening 22 in the nozzle 23 and thus shuts off the supply of the second liquid.

Preferably both liquids are shut off at the same time, so that no excess of either liquid may be allowed to enter the combustion chamber.

In Fig. 6 I have indicated diagrammatically a form of operating mechanism by which the valve heads 21 and 36 may be simultaneously moved to closed positions. For this purpose the valve rod 20 is connected to a bell crank 40 pivoted at 41, and the valve rod 35 is connected to a lever 42 pivoted at 43.

The upper ends of the bell crank 40 and lever 42 are connected to a piston rod 44 operated by a piston 45 in a cylinder 46 to which is connected a pressure supply pipe 47. When a gas or liquid under pressure is supplied to the cylinder 46, the piston 45 will be effective through the described connections to simultaneously move the valve rod heads 21 and 36 to the positions in which the supply of liquids through the pipes 14 and 15 is positively shut off.

Under actual test, my improved combustion apparatus has proved highly successful and efficient. As the liquid entering under pressure through the pipe 14 strikes the cup-shaped head 21 of the valve, the liquid is deflected and caused to spread rearward and outward in the form of a conical spray, more or less closely adjacent the

conical inner end wall 12 of the combustion chamber.

At the same time, the second liquid enters through the pipe 15 in a tangential direction and under such pressure that it whirls around closely adjacent the outer cylindrical wall 10 of the combustion chamber. The two streams or sprays of liquid are thus traveling at high speed in directions substantially perpendicular to each other, thus effecting a very thorough and complete mixture of the liquids and with very complete combustion resulting from such mixture.

The products of combustion flow outward away from the conical inner end wall 12 in the direction of the arrows *a* in Fig. 1 and escape through an outwardly enlarged nozzle portion as indicated at 50 in Fig. 4, when the invention is embodied in a rocket construction.

The provision of flat base or flange 25 at the outer edge of the conical inwardly projecting end wall 12 provides increased space for combustion at the periphery of the chamber where the mixture of the two liquids is most complete.

In Fig. 4, I have shown my invention embodied in a combustion chamber 52 of substantially spherical shape to which a nozzle 50 may be attached as previously described. The inverted conical rear wall 53 has its base 54 secured to the inner surface of the spherical chamber 52, and the construction and operation is otherwise as previously described. Perforations in the wall 53 are indicated at 55. This form of my invention provides the greatest possible strength for the weight of metal involved.

In Fig. 5, I have shown a construction similar to that appearing in Fig. 1 except for the omission of the semi-spherical outer rear end wall 11 and also for the omission of the perforations 26 in the conical end wall 60. With this form of my invention, the results are closely similar to those obtained by the use of the construction shown in Fig. 1, but somewhat heavier metal is required for the end wall 60, as in this case the wall 60 must resist the rearward pressure in the combustion chamber 61.

All forms of the invention, however, possess the important advantage that the combustion chamber has increased capacity near the peripheral outer walls where the mixture of liquids is most complete, and has decreased capacity near the center where the liquids will be only slightly intermingled. The position of the valve heads 21 and 36 closely adjacent the restricted openings 22 and 33 is of substantial importance as the closing of the valves at these points insures that the supply pipes each contain only one kind of liquid, so that no explosive mixture can be formed in either supply pipe after the valves have been closed.

It will be understood that the mechanism shown in Fig. 6 is diagrammatic and illustrative only and that any other suitable operating mechanism may be substituted.

Having thus described my invention and the advantages thereof, I do not wish to be limited to the details herein disclosed, otherwise than as set forth in the claims, but what I claim is:—

1. In combustion apparatus employing liquid combustible and oxidizing agents, a combustion chamber having a substantially conical member forming the major part of the effective rear end wall of said chamber and projecting inwardly and toward the outlet of said chamber, means to admit one of said liquids near the center of said conical end wall, means to deflect said liquid

outwardly and rearwardly in a conical spray along said wall and away from the outlet of said chamber, and means to admit the second liquid at the periphery of said combustion chamber and adjacent the base of said end wall, said second liquid entering said chamber substantially tangentially at the periphery thereof and adjacent the base of said conical end wall and traveling circumferentially in said chamber and substantially perpendicular to the path of movement of said first liquid.

2. In combustion apparatus employing liquid combustible and oxidizing agents, a combustion chamber having a substantially conical member forming the major part of the effective rear end wall of said chamber and projecting inwardly and toward the outlet of said chamber, a supply pipe for one of said liquids entering said chamber through the center of said conical end wall, means to deflect said liquid outwardly and rearwardly in a conical spray along said wall and away from the outlet of said chamber, and a second supply pipe for the second liquid entering said chamber at the periphery of said chamber and adjacent the base of said end wall, said second liquid entering said chamber in a substantially tangential direction and traveling circumferentially in said chamber and substantially perpendicular to the path of movement of said first liquid.

3. In combustion apparatus employing liquid combustible and oxidizing agents, a combustion chamber having a substantially conical member forming the major part of the effective rear end wall of said chamber and projecting inwardly and toward the outlet of said chamber, a device to admit one of said liquids near the center of said conical end wall, means to deflect said liquid outwardly and rearwardly in a conical spray along said wall and away from the outlet of said chamber, a device to admit the second liquid at the periphery of said combustion chamber and adjacent the base of said end wall, said second liquid entering said chamber substantially tangentially and traveling circumferentially in said chamber and substantially perpendicular to the path of movement of said first liquid, the points of entry of said two liquids being widely spaced apart, and means to simultaneously close said admitting devices for both liquids closely adjacent the widely separated points of entrance of said two liquids to said chamber.

4. In combustion apparatus employing liquid combustible and oxidizing agents, a combustion chamber having an outwardly arched outer rear end wall, a substantially conical inner end wall spaced from said outer wall and projecting toward the outlet of said chamber, said latter wall having perforations therethrough, means to supply one of said liquids to said combustion chamber in the form of an outwardly and rearwardly directed conical spray adjacent the inner face of said inner end wall, and means to supply the second liquid to said chamber in the form of a circumferentially moving jet adjacent the outer edge portion of said conical inner end wall and adjacent the periphery of said combustion chamber.

5. In combustion apparatus employing liquid combustible and oxidizing agents, a combustion chamber having an outwardly arched outer rear end wall, a substantially conical inner end wall spaced from said outer wall and projecting toward the outlet of said chamber, said latter wall having perforations therethrough, means to sup-

ply one of said liquids to said combustion chamber in the form of an outwardly and rearwardly directed conical spray adjacent the inner face of said inner end wall, means to supply the second liquid to said chamber in the form of a circumferentially moving jet adjacent the outer edge portion of said conical inner end wall the points of entry of said two liquids being widely spaced apart, and means to simultaneously interrupt the flow of both liquids closely adjacent their widely separated points of entry into said combustion chamber.

6. In combustion apparatus employing liquid combustible and oxidizing agents, a combustion chamber having an arched outer rear end wall, an inwardly projecting and substantially conical inner end wall spaced from said outer rear wall, said inner wall having perforations there-through communicating with the enclosed space between said end walls, means to supply one of said liquids to said combustion chamber in the form of an outwardly and rearwardly directed conical spray adjacent said inner end wall and moving away from the outlet of said chamber, and means to supply the second liquid to said chamber in the form of a circumferentially moving jet adjacent and in front of the outer edge

portion of said conical inner end wall, said conical end wall having a relatively narrow annular flat base portion secured to the side wall of said combustion chamber.

7. In combustion apparatus employing liquid combustible and oxidizing agents, a combustion chamber having an arched outer rear end wall, an inwardly projecting and substantially conical inner end wall substantially spaced from said outer wall, said inner wall having perforations therethrough and having a substantially flat and relatively narrow outer annular base portion, means to admit one of said liquids near the center of said conical inner end wall, means to deflect said liquid outwardly and rearwardly in a conical spray along said inner wall portion and base and away from the outlet of said chamber and means to admit the second liquid at the periphery of said combustion chamber and in front of and adjacent the base of said inner end wall, said second liquid entering said chamber substantially tangentially and traveling circumferentially in said chamber and substantially perpendicular to the path of movement of said first liquid.

ROBERT H. GODDARD.